

# ONKYO® SERVICE MANUAL


## COMPACT DISC PLAYER MODEL DX-1700



### Black model

BUD	120V AC, 60Hz
BUG	220V AC, 50Hz
BUU	110/120/220/240V AC, 50/60Hz
BUQA, BUQB	240V AC, 50 Hz

### SAFETY-RELATED COMPONENT WARNING!!

COMPONENTS IDENTIFIED BY MARK  ON THE SCHEMATIC DIAGRAM AND IN THE PARTS LIST ARE CRITICAL FOR RISK OF FIRE AND ELECTRIC SHOCK. REPLACE THESE COMPONENTS WITH ONKYO PARTS WHOSE PART NUMBERS APPEAR AS SHOWN IN THIS MANUAL.

MAKE LEAKAGE-CURRENT OR RESISTANCE MEASUREMENTS TO DETERMINE THAT EXPOSED PARTS ARE ACCEPTABLY INSULATED FROM THE SUPPLY CIRCUIT BEFORE RETURNING THE APPLIANCE TO THE CUSTOMER.

### SPECIFICATIONS

Signal readout system:	Optical non-contact
Reading rotation:	About 500~200 r.p.m. (constant linear velocity)
Linear velocity:	1.2~1.4m/s
Error correction system:	Cross interleave readsolomon code
Decoded bits:	16 bits linear
Sampling frequency:	352.8kHz (8 times oversampling)
Number of channels:	2 (stereo)
Frequency response:	5Hz~20kHz
Total harmonic distortion:	0.004% (at 1kHz)
Dynamic range:	96dB
Signal to noise ratio:	100dB
Channel separation:	90dB (at 1kHz)
Wow and Flutter:	Below threshold of measurability
Power consumption:	16 watts
Output level:	2 volts r.m.s.
Dimensions (W x H x D):	435x119x312mm 17-1/8"x4-11/16"x12-1/4"
Weight:	4.7kg, 10.4lbs.

Specifications are subject to change without notice.

**ONKYO**  
**AUDIO COMPONENTS**

## TABLE OF CONTENTS

Specifications . . . . .	1
Service procedures . . . . .	2
Portection on eyes from laser beam during servicing . . . . .	2
Laser warning labels . . . . .	2
Caution on replacement of pickup . . . . .	4
Exploded view-parts list . . . . .	4
Exploded view . . . . .	5
Mechanism-exploded view . . . . .	6
Parts list . . . . .	7
Disassembling procedures . . . . .	8
Adjustment procedures . . . . .	12
Trouble shooting guide . . . . .	15
IC block diagram and description . . . . .	17
Microcomputer descriptions . . . . .	23
Schematic diagram . . . . .	25
Waveform of each section . . . . .	29
Pc board view & Parts list . . . . .	31
Block diagram . . . . .	35
Packing view . . . . .	36

## SERVICE PROCEDURES

### 1. Safety-check out

After correcting the original service problem, perform the following safety check before releasing the set to the customer:

Connect the insulating-resistance tester between the plug of power supply cable and chassis.

Specifications: more than 10Mohm at 500V.

### 2. Voltage selector (rear panel)

Worldwide models are equipped with a voltage selector to conform with local power supplies. Be sure to set this selector to match the voltage of the power supply in your area before turning the power switch on. Voltage is changed by turning the voltage selector with a screwdriver or similar instrument to the 110V, 120V, 220V or 240V position. Confirm that the selector has been set to the correct position before turning the power switch on. If there is no voltage selector switch on the unit you have purchased, it can only be used in areas where the power supply voltage is the same as that of the unit.

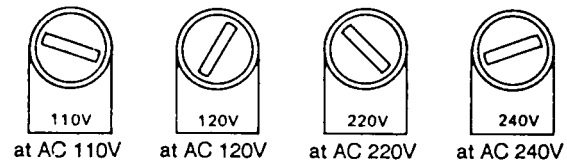


Fig. 1

## PROTECTION OF EYES FROM LASER BEAM DURING SERVICING

This set employs a laser. Therefore, be sure to follow carefully the instructions below when servicing.

### WARNING!!

WHEN SERVICING, DO NOT APPROACH THE LASER EXIT WITH THE EYE TOO CLOSELY. IN CASE IT IS NECESSARY TO CONFIRM LASER BEAM EMISSION, BE SURE TO OBSERVE FROM A DISTANCE OF MORE THAN 30cm FROM THE SURFACE OF THE OBJECTIVE LENS ON THE OPTICAL PICK-UP BLOCK.

### Laser Diode Properties

- Material: GaAS/GaAlAs
- Wavelength: 780nm
- Emission Duration: continuous
- Laser output: max. 0.5mW\*

\*This output is the value measured at a distance about 1.8mm from the objective lens surface on the Optical Pick-up Block.

## LASER WARNING LABEL

The label shown below are affixed.

### 1. Certification label (120V model)

This label is located on the back panel.

PRODUCT IS CERTIFIED BY THE MANUFACTURER TO COMPLY WITH DHHS RULES 21 CFR SUBCHAPTER J APPLICABLE AT THE DATE OF MANUFACTURE.

MANUFACTURED

Fig. 2

### 2. Class 1 label (Except 120V model)

This label is located on the back panel.

"CLASS 1 LASER  
PRODUCT"

Fig. 3

### 3. Warning lable

This label is located on the arm of mechanism.

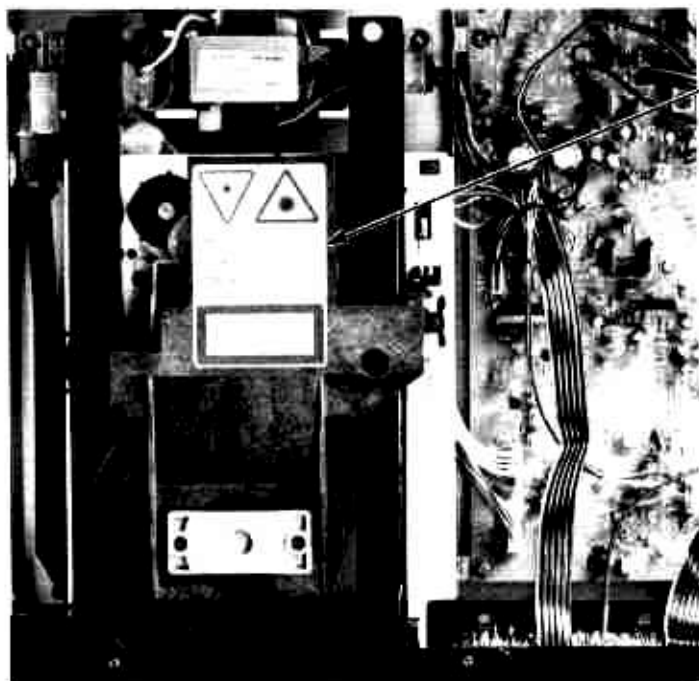


Photo 1



**DANGER** —INVISIBLE LASER RADIATION WHEN OPEN AND INTERLOCK FAILED OR DEFEATED. AVOID DIRECT EXPOSURE TO BEAM

**CAUTION** —HAZARDOUS LASER AND ELECTROMAGNETIC RADIATION WHEN OPEN AND INTERLOCK DEFEATED

**ATTENTION** —RAYONNEMENT LASER ET ELECTROMAGNETIQUE DANGEREUX SI OUVERT AVEC L'ECLenchEMENT DE SECURITE ANNULE

SN29360911

ADVARSEL: USYNLIG LASERSTRÅLING VED ÅBNING, NÅR SIKKERHEDSAFBRYDER ER UDE AF FUNKTION. UNDGÅ UDSÆTTELSE FOR STRÅLING.

Fig. 4

### ADVARSEL

"CLASS 1 LASER PRODUCT"

Denne mærkning er anbragt på apparatets højre side og indikerer, at apparatet arbejder med laserstråler af klasse 1, hvilket betyder, at der anvendes laserstråler af svageste klasse, og at man ikke på apparatets yderside kan blive udsat for utilladelig kraftig stråling.

APPARATET BØR KUN ÅBNES AF FAGFOLK MED SÆRLIGT KENDSKAB TIL APPARATER MED LASERSTRÅLER!

Indvendigt i apparatet er anbragt den her gengivne advarselmærkning, som advarer imod at foretage sådanne indgreb i apparatet, at man kan komme til at udsætte sig for laserstråling.

ADVARSEL: USYNLIG LASERSTRÅLING VED ÅBNING, NÅR SIKKERHEDSAFBRYDER ER UDE AF FUNKTION. UNDGÅ UDSÆTTELSE FOR STRÅLING.

VAROITUS! Laite sisältää laserdiodin, joka lähettää (näkymätöntä) silmille vaarallista lasersäteilyä.

Fig. 5

## CAUTION ON REPLACEMENT OF PICKUP

The laser diode in the optical pickup block is so sensitive to static electricity, surge current and etc. that the components are liable to be broken down or its reliability remarkably deteriorated.

During repair, carefully take the following precautions. (The following precautions are included in the service parts).

### PRECAUTIONS

#### 1. Ground for the work-desk.

Place a conductive sheet such as a sheet of copper (with impedance lower than  $10^6 \Omega$ ) on the work-desk and place the set on the conductive sheet so that the chassis.

#### 2. Grounding for the test equipment and tools.

Test equipments and toolings should be grounded in order that their ground level is the same the ground of the power source.

#### 3. Grounding for the human body.

Be sure to put on a wrist-strap for grounding whose other end is grounded.

Be particularly careful when the workers wear synthetic fiber clothes, or air is dry.

#### 4. Select a soldering iron that permits no leakage and have the tip of the iron well-grounded.

#### 5. Do not check the laser diode terminals with the probe of a circuit tester or oscilloscope.

### Care should be taken with the optical pickup.

The optical pickup is sensitive to static electricity, surge currents, and other high electrical noise, and because there is the possibility of damage to performance, in the handling of the pickup, the utmost care must be taken, particularly with regard to static electricity.

- When checking the laser terminal, avoid making connections using the probes of a tester or oscilloscope, or an ordinary power supply.
- When replacing the optical pickup, first short the LD terminals and remove the connector. Also, when attaching the new optical pickup, after attaching the connector, unsolder the LD terminals.

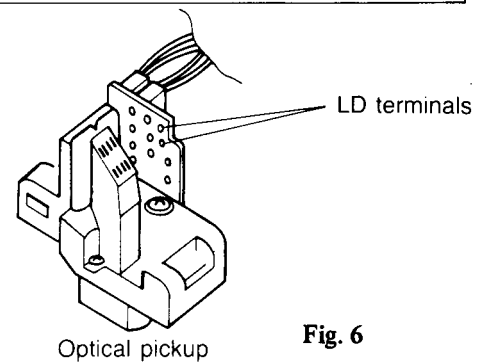


Fig. 6

## EXPLODED VIEW-PARTS LIST

REF.NO.	PART NO.	DESCRIPTION
1	27100190	Chassis
2	27121237	Back panel <D>
	27121238	Back panel <G>
	27121239	Back panel <W>
	27121238-2	Back panel <QA/QB>
4	27300750	△ Bushing, cord (Strainrelief)
5	27190266	KGLS-12R, Holder
6	28140946	Cushion (Main circuit pc board)
7	27273112	Joint, power
9	27270214A	Spacer
11	27190706B	Holder, mechanism
13	27141340	Bracket L
15	830440109	4TTC+10C(BC), Tapping screw
16	834430088	3TTS+8B(BC), Tapping screw
17	833430080	3TTP+8P(BC), Tapping screw
18	831130088	3TTW+8B, Tapping screw
19	834430108	3TTS+10B(BC), Tapping screw
20	833426060	2.6TTP+6P(BC), Tapping screw
26	27110477	Front bracket ass'y
31	28184429	Top cover
33	834430088	3TTS+8B(BC), Tapping screw
51	1H073121	Front panel ass'y
58	27211085A	Tray panel
71	28191512	Clear plate
72	833430080	3TTP+8P(BC), Tapping screw
74	27270255	Spacer
76	27175153	Leg
77	834430088	3TTS+8B(BC), Tapping screw
81	801364	Special screw
82	801414	Special screw
83	27175011C	Leg(Cushion)

NOTE: <D>: Only 120V Models      <QB>: Only U.K. Models  
<G>: Only 220V Models      <W>: Only Worldwide Models  
<QA>: Only Australian Models

85	29360911	Label, caution, laser
86	29360840	Label, certification <D>
87	29360687	Label CLASS 1 <G/W/QA/QB>
88	28175158A	Insulator plate <G/W/QA/QB>
91	27141090A	Bracket U <W>
92	834430088	3TTS+8B(BC), Tapping screw <W>
P921	253099C	△ AS-UC-3, Power supply cord <D>
	253148 or	△ AS-CEE 250V 2.5A,
	253150	Power supply cord <G/W>
	253118	△ AS-SAA, Power supply cord <QA>
	728328	△ 2-0.75BS16, Power supply cord <QB>
S902	25065168	△ HXW0131-01-060, Voltage selector switch <W>
T901	2300384B	△ NPT-1015D, Power transformer <D>
	2300385B	△ NPT-1015G, Power transformer <G>
	2300387B	△ NPT-1015ADGQ, Power transformer <W>
	2300386B	△ NPT-1015Q, Power transformer <QA/QB>
U1	1H073542-1	NAAR-3542-1, Main circuit pc board ass'y <D/W>
	1H073542-1A	NAAR-3542-1A, Main circuit pc board ass'y <G/QA/QB>
U2	1H073543-1	NADIS-3543-1, Display circuit pc board ass'y
U3	1H073544-1	NAAF-3544-1, Headphone amplifier pc board ass'y
U4	1H073545-1	NAPS-3545-1, Power supply pc board ass'y
U5	1H073546-1	NAETC-3546-1, Syncro terminal pc board ass'y
L901	230908	TR-23-11-14Core(2nd side of power transformer) <D>
	230907	TR-16-8-16 Core<G/w/QA/QB>

EXPLODED VIEW

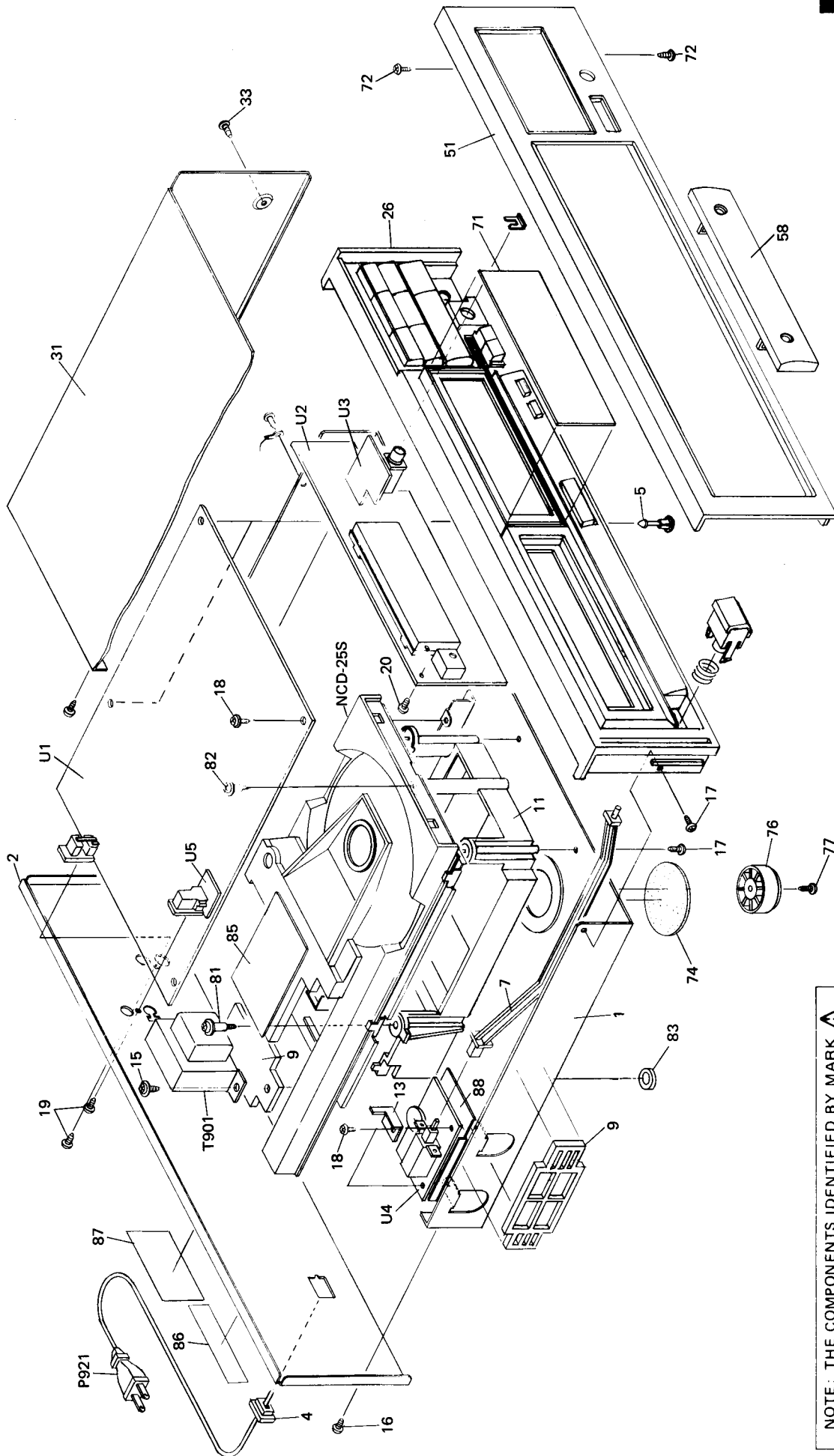

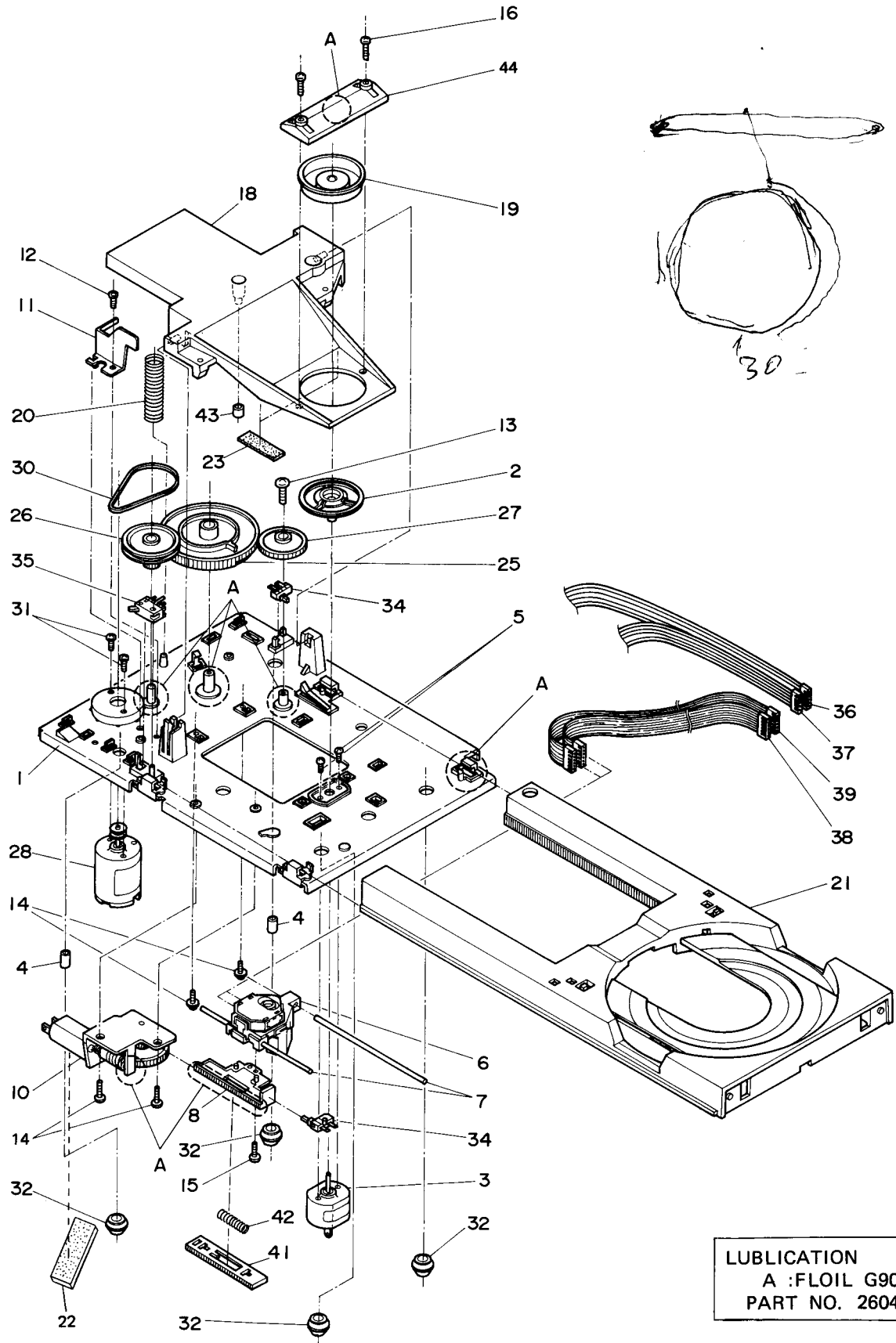


Fig. 7

NOTE: THE COMPONENTS IDENTIFIED BY MARK  ARE CRITICAL FOR RISK OF FIRE AND ELECTRIC SHOCK. REPLACE ONLY WITH PART NUMBER SPECIFIED.

**MECHANISM-EXPLODED VIEW**



**Fig. 8**

## PARTS LIST

REF.NO.	PART NO.	DESCRIPTION	REF.NO.	PART NO.	DESCRIPTION
1	27100188A	Mechanism chassis	22	28140941	Cushion
2	27301201	Turntable	23	28140947	Cushion
3	24502243	Spindle motor	25	27300942C	Cam gear
4	28140948	Tube	26	27300943	Pulley gear
5	82142003	2P+3F(BC), Pan head screw	27	27300944A	Gear
6	24110001	KSS-152A, Optical pickup	28	1H025901	Tray motor ass'y
7	27260222	Shaft	30	27301079	Belt
8	27301191	Rack A	31	82143004	3P+4FN(BC), Pan head screw
10	1H073902	Slide motor ass'y	32	27301107	Cushion, rubber
11	27141230	Bracket, holder	34	25065321	NMS-1113, Microswitch (S002/S003)
12	834430068	3TTS+6B(BC), Tapping screw	35	25065322	NMS-1214, Microswitch (S001)
13	831126060	2.6TTW+6P, Tapping screw	36	2000733B	NSAS-6P689, Socket ass'y, motors
14	831430100	3TTW+10P(BC), Tapping screw	37	2000734B	NSAS-6P690, Socket ass'y, microswitches
15	833420068	2TTP+6P(BC), Tapping screw	38	2000952	NSAS-8P904, Socket ass'y, white
16	<del>833426060</del>	<del>2.6TTP+6P(BC), Tapping screw</del>	39	2000951	NSAS-8P903, Socket ass'y, red
18	27301190	Arm	41	27301192A	Rack B
19	27300848A	Cap CH	42	27180426	Spring
20	27180341A	Spring	43	27301189	Cap, arm
21	27301202A	Disc tray ass'y	44	<del>27300849C</del>	<del>Holder, cap</del>

## DISASSEMBLING PROCEDURES

### Method for removing the tray

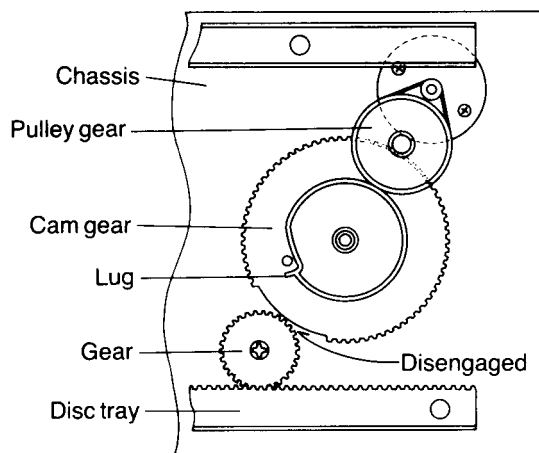


Fig. 9

1. Set the position so that the cam gear and gear are disengaged.
2. Pull the tray to the front.

### Method for removing disc motor

1. Remove the tray.
2. Remove the holder, then remove the arm.
3. Remove the 3 screws that fasten the mechanism chassis to the main chassis.
4. Cut the turntable platter with a nipper.
5. Remove the soldering of the disc motor, and remove the 2 fastening screws.
6. When inserting the turntable platter onto the motor shaft, hold the platter at a right angle to the motor shaft and push it onto the shaft until it touches the bottom.

NOTE: Height of turntable platter.  
See page 14.

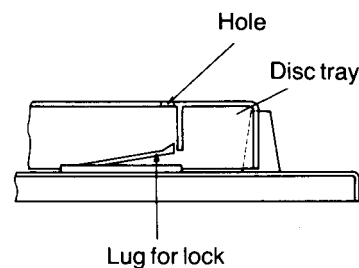


Fig. 10

3. Insert a small flat-bladed screw driver into the hole section of the right side of the back of the tray, and push the lug used for locking the tray to bring the tray to the front.

CAUTION: When inserting the tray, the cam gear and gear parts are not in the meshing position.

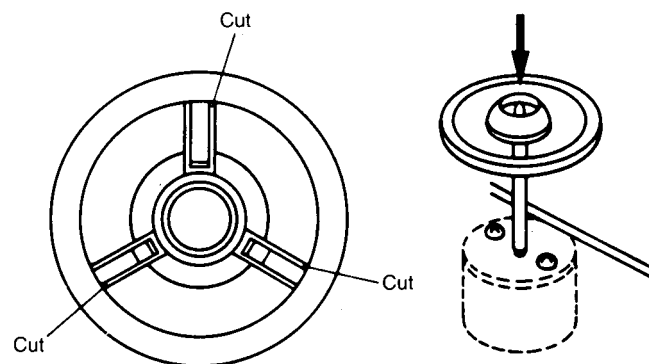


Fig. 11



## CIRCUIT DESCRIPTIONS

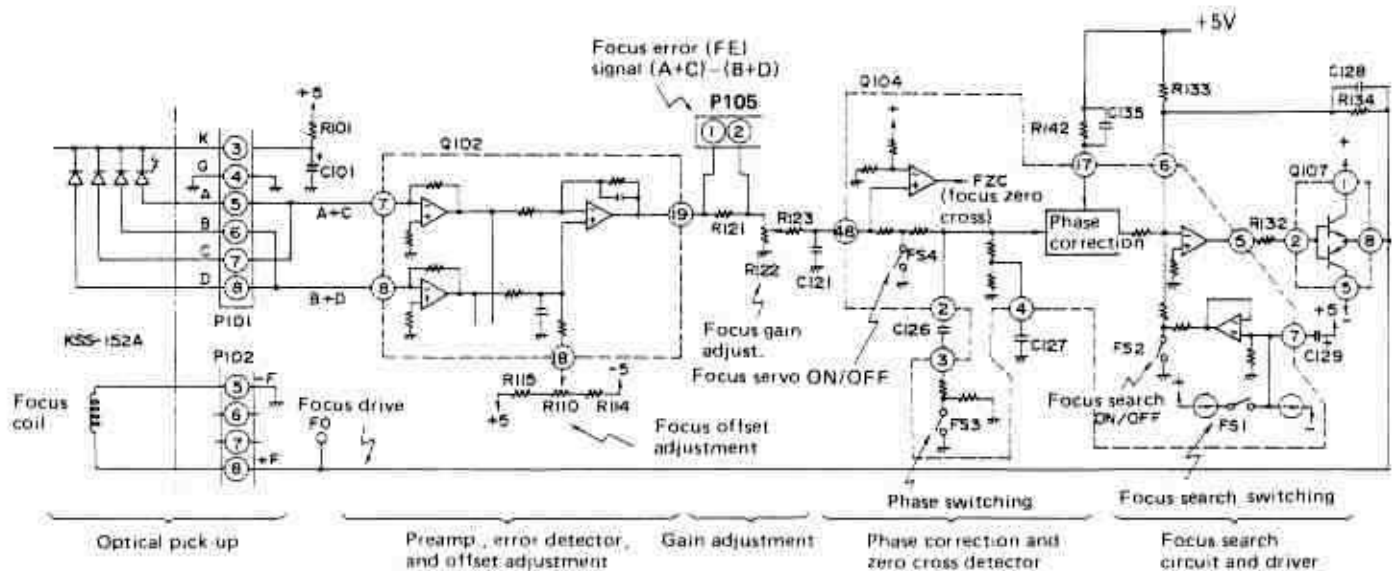


Fig. 12 Focus servo circuit

### 1. Focus servo circuit

From the optical pickup objective lens, the emitted laser beam is focused on the disc reflecting surface, and this circuit controls the movement of the lens up and down.

#### 1-1. Error detecting circuit

The error is detected by means of the astigmatic aberration method and obtains its focus error signal from the optical pickup output signal  $(A+C) - (B+D)$ .

The individual signals  $(A+B)$  and  $(C+D)$  input to pins 7 and 8 of Q102 are subtracted by means of the IC internal op amp, and from pin 19, the F.E. signal is output. Also, in order to eliminate the focus error, offset adjustment is carried out by the semi-fixed resistor R110 of pin 18 of Q102.

#### 1-2. Phase correction and driver circuit

By means of the semi-fixed resistor R122, the gain adjusted F.E. signal passes by way of the phase correction circuit from pin 48 of Q104, and from pin 5 of Q104 to the driver Q107, and is feedback to the coil used for driving the optical pickup KSS-152A objective lens. In addition, there are the FS4 servo ON/OFF switch and FS3 phase characteristic selector switch.

#### 1-3. Focus zero cross circuit and focus search circuit

In order to have mandatory drive of the objective lens in the capture range of only  $10\mu\text{m}$  at the focus-point it is necessary to turn off the above mentioned FS4 and close the servo loop. The timing diagram for that operation is shown in Fig.13.

The triangular wave generated by means of the focus search circuit internal to Q104 shifts the objective lens up/down direction, and at the correct focus point, the fall of F.E. signal is detected by the focus zero cross (FZC) circuit to close the servo loop. At this time, it is necessary that the focus OK (FOK) signal be in the high level. In Fig.13, the dotted line is the waveform of the focus capture failure.

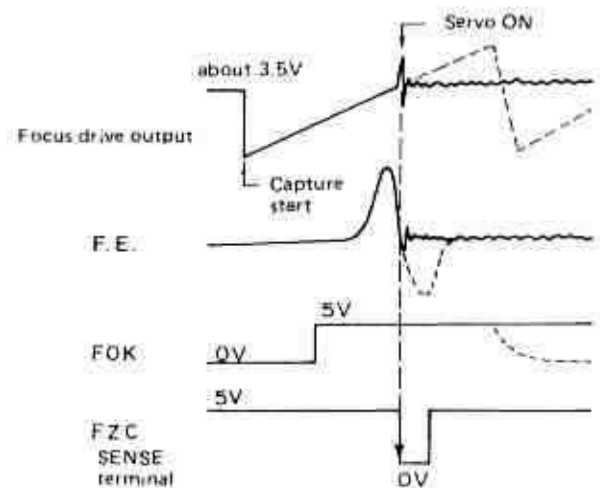


Fig. 13 Capture operation of focus

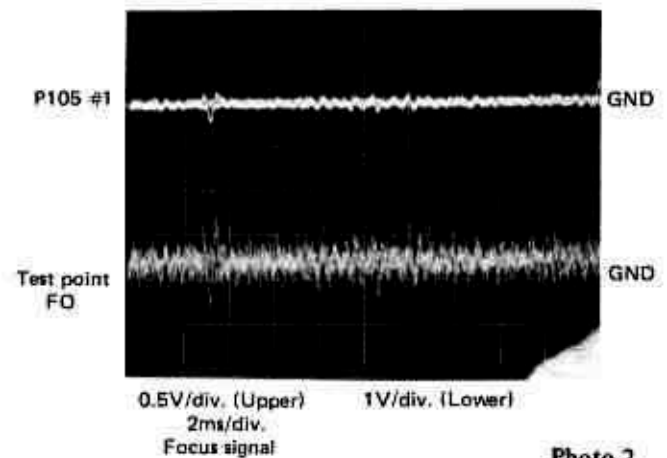


Photo 2



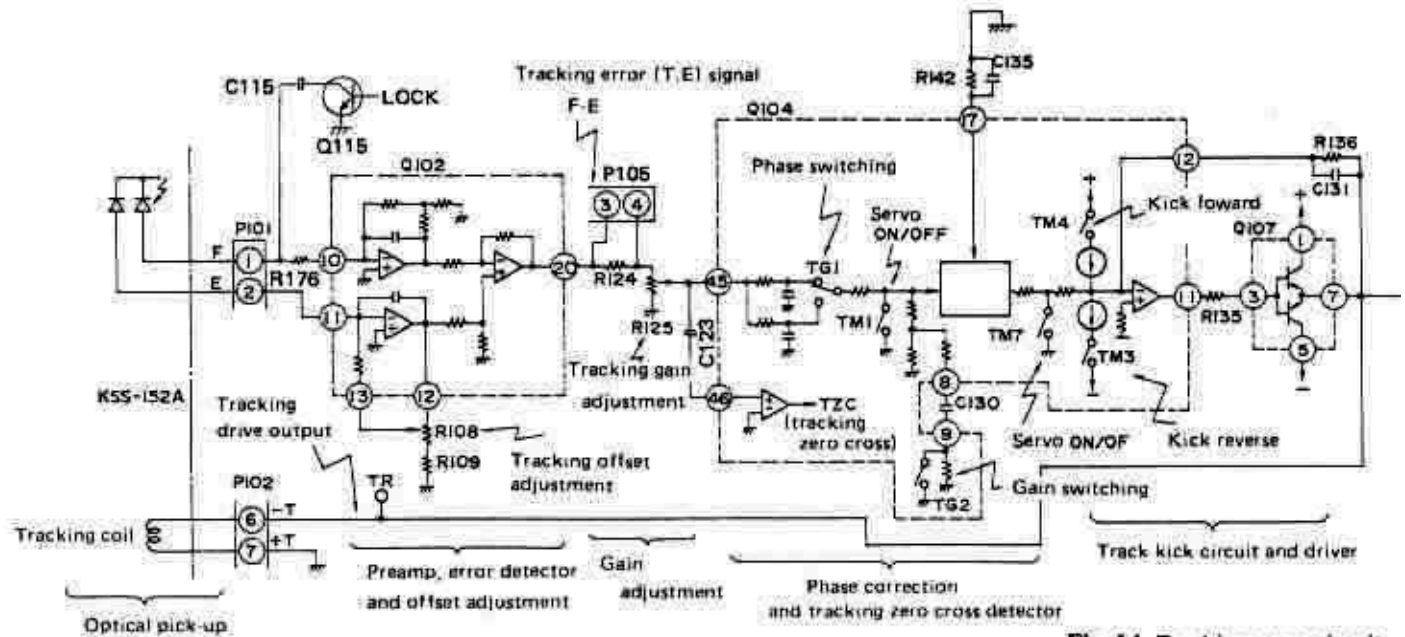


Fig. 14 Tracking servo circuit

## 2. Tracking servo circuit

On the disc at a pitch of  $1.6\mu\text{m}$ , the laser beam accurately traces the center of the pits cut into the disc, and this is the control circuit that shifts the objective lens in the radial direction.

### 2-1. Error detection circuit

The F-E is obtained from the tracking error (T.E.) signal by means of a 3 beam method. The F.E. signal input to pins 10 and 11 of Q102 is subtracted internally, and is output as the T.E. signal from pin 20. R108 is the semi-fixed resistor control for tracking offset.

### 2-2. Phase correction and driver circuit

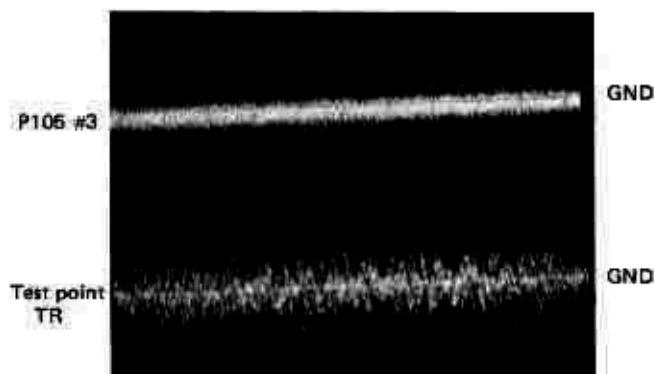
The T.E. signal adjusted for gain by means of the semi-fixed resistor R125 passes through the phase correction circuit from pin 45 of Q104, and from pin 11 by way of driver Q107 objective lens. TM1 and TM7 are used as the tracking servo ON/OFF switches, and TG1 and TG2 respectively are used as the phase selector and gain selector switches.

### 2-3. Tracking zero cross and track kick circuit

At the time the head comes out and when there is manual fast forward, in the event that it is necessary to skip over the track being traced, the T.E. signal receives a kick pulse, and by means of this, shifting of the objective lens can be achieved.

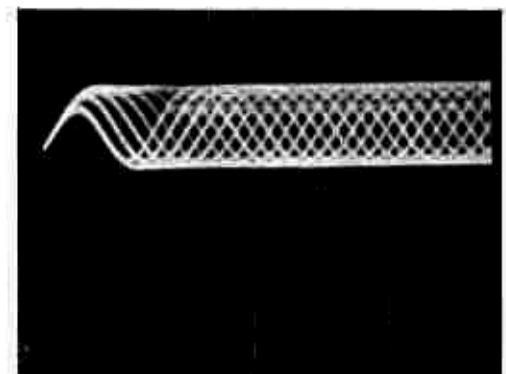
TM3 and TM4 respectively are the switches for providing the forward and reverse direction kick pulses. Also, the tracking zero cross (T.Z.C.) circuit counts the number of tracks skipped over and produces the signal in order to determine the timing of the servo ON/OFF.

The ON/OFF command for these switches is output from the microcomputer.



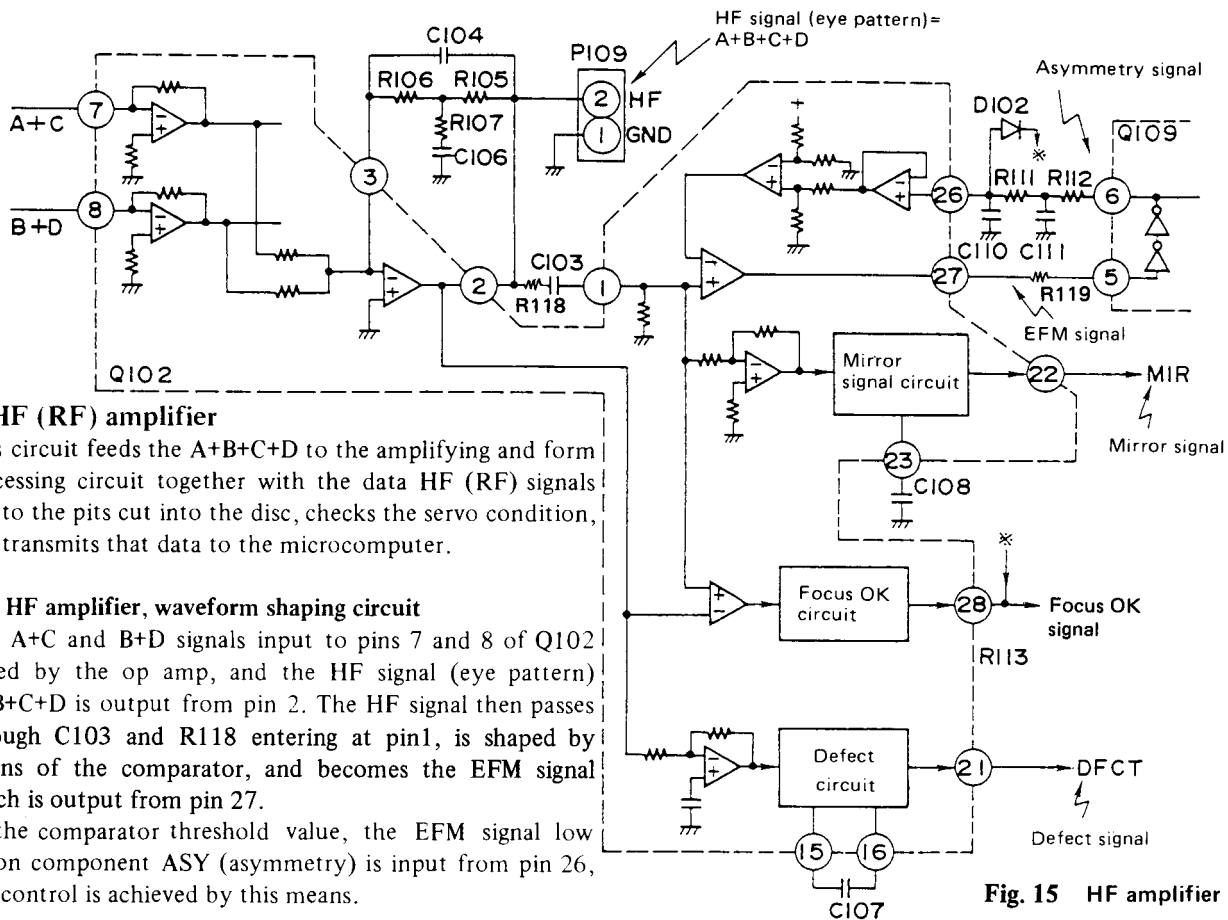
0.5V/div. 0.5ms/div.  
Tracking signal

Photo 3



0.2  $\mu\text{s}/\text{div}$ . 0.5mV/div.  
Signal HF (RF)  
Play the track 2 of YEDS-18.

Photo 4



**Fig. 15 HF amplifier circuit**

**3. HF (RF) amplifier**

This circuit feeds the A+B+C+D to the amplifying and form processing circuit together with the data HF (RF) signals due to the pits cut into the disc, checks the servo condition, and transmits that data to the microcomputer.

**3-1. HF amplifier, waveform shaping circuit**

The A+C and B+D signals input to pins 7 and 8 of Q102 added by the op amp, and the HF signal (eye pattern) A+B+C+D is output from pin 2. The HF signal then passes through C103 and R118 entering at pin1, is shaped by means of the comparator, and becomes the EFM signal which is output from pin 27.

In the comparator threshold value, the EFM signal low region component ASY (asymmetry) is input from pin 26, and control is achieved by this means.

**3-2. MIR circuit, FOK circuit, and DFCT circuit**

After the HF signal is processed the detection, shaping, etc, respectively the MIR, FOK, and DFCT signals are output from pins 22, 28, and 21.

**3-2-1. MIR (mirror) signal**

When the head is extended, at the time the signal becomes high at the disc track and between tracks, the number of tracks is counted, and this is used for determining the timing for the ON/OFF of the servo.

**3-2-2. FOK (focus OK) signal**

This signal goes high at the time the focus servo is required. (Refer to 1-3)

**3-2-3. DFCT (defect) signal**

If there is a defect (scratch, dirt, etc.) in the disc, this signal goes high, the servo and gain are controlled, and the circuit prevents a sound outburst.

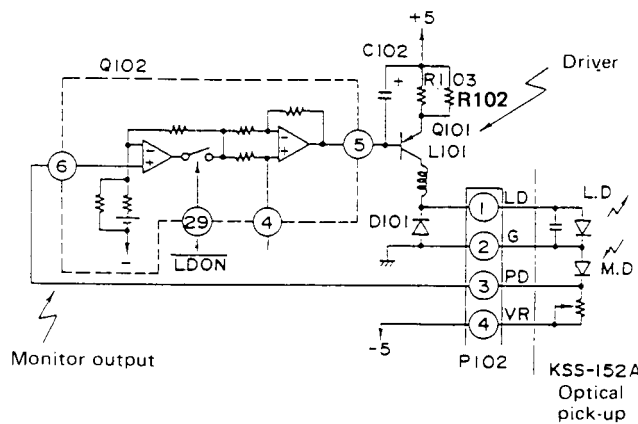
**4. APC circuit**

By means of feedback from the monitor, this circuit controls the light output due to a bad condition resulting from the temperature characteristic of the laser diode.

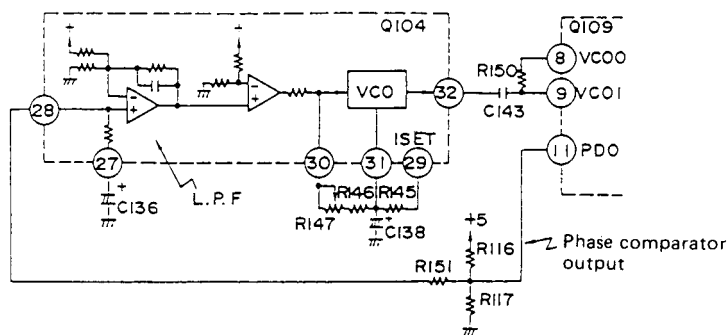
For the pin 29 LDON (laser diode ON) signal, when the APC ON/OFF control signal is LOW, the laser is emitted.

**5. CLV servo circuit**

In the compact disc there is a CLV system (constant linear velocity), and at the replay position, because the disc rotary speed varies, the clock is taken out of the HF signal, and



**Fig. 16 APC circuit**



**Fig. 17 PLL circuit**

the PLL circuit and its clock must be synchronized to control the spindle motor.

**5-1. PLL circuit**

As shown in Fig. 6, for the phase comparator, in Q109 the LPF and VCO are each built into Q104. The semi-fixed resistor R147 is the control for adjusting the 8.6436 MHz free run frequency (WFCK = 7.35 KHz).

**5-2. Spindle motor control circuit**

The output of the phase comparator (MDP) and frequency comparator (MDS) from pins 3 and 4 of Q109 is fed to pins 34 and 36 of Q104. Also, the spindle motor ON/OFF signal (MON) from pin 2 of Q109, and the phase selector signal (FSW) from pin 1, are output and fed to pin 36 of Q104. After these signals are processed in Q104, they are passed from pin 39 through the driver Q108, and are supplied to the spindle motor.

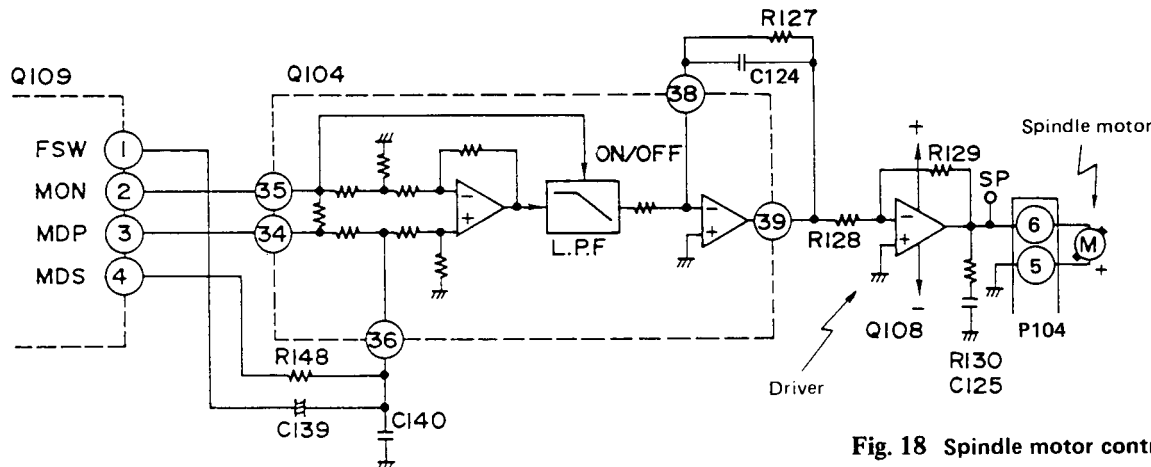


Fig. 18 Spindle motor control circuit

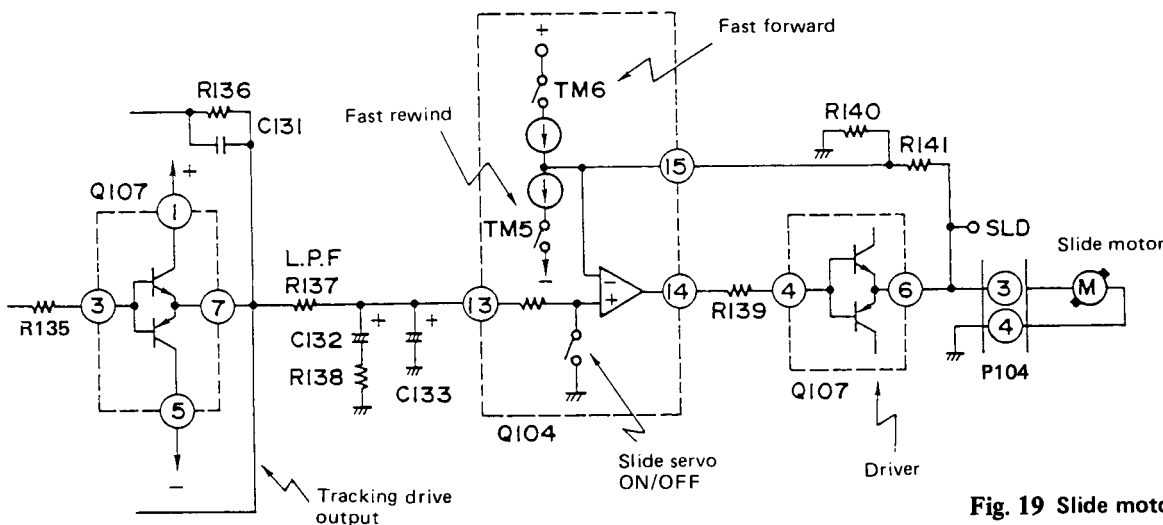
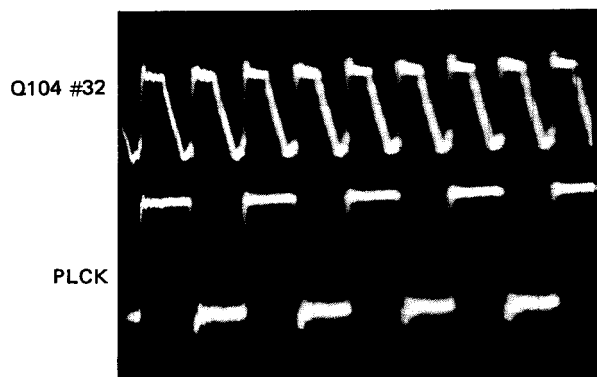


Fig. 19 Slide motor circuit

**6. Slide motor circuit**

This circuit controls the slide motor which is used for moving the optical pickup from inside the disc to the outside. In the normal playback time, the low region component of the tracking driver output is amplified and fed to the motor, but when the head is extended, switches TM5 and TM6 internal to Q104 control the ON/OFF.



1V/div. (Upper) 2V/div. (Lower)  
0.1 μs/div.

Photo 5

# MICROCOMPUTER DESCRIPTIONS

M50941-186SP

Pin No.	Symbol	I/O	Description
1	Vref		Power supply reference of microcomputer.
2 ~ 5	IN7 ~ IN4	I	Key input terminals (A/D converter).
10~13	DATA 3~DATA 0	I/O	DATA bus terminals.
14	SCLK	I	Status transfer clock input from Q751.
16	MCLK	O	Command transfer clock output to Q751.
17	CMND	O	Command transfer signal output to Q751."L" active.
18	NRSC OUT	O	NRSC(RI) code output terminal.
24	NRSC IN	I	NRSC(RI) code input terminal.
26,30	GND		Ground terminals.
27	XRST	I	Reset input terminal.Reset at high level from low when power is turned on.
28	C4M	I	Reference clock input terminal. f=4.2336MHz
32	Vss		Connect to ground.
34,36	GND		Ground terminals.
35,37	+5V		Connect to +5V.
38	-Vdisp		Connect to -24V. Power supply terminal of FL tube.
39~54	a~p	O	Segment output terminals for FL tube.
55~62	1G~8G	O	Grid output terminals for FL tube.
63	AVcc		Power supply terminal for A/D converter(#2,3,4 and 5).Connect to +5V.
64	Vcc		+5V power supply terminal.

MB88505HP-G-1041T-SH

Pin No.	Symbol	I/O	Description
1 ~ 4	DATA 0~DATA 3	I/O	Data bus terminals.
5	CMND	I	Command transfer signal terminal from Q701."L" active.
6	MCLK	I	Command transfer clock terminal from Q701.
7	SENS	I	Servo IC (Q104) and signal processing IC (Q109) sense information input terminal.
8	FOK	I	Focus input terminal. "H" when focus is on.
9 ~ 11	+5V	I	+5V power supply terminal.
12	IN SW	I	Loading IN switch information terminal."L" when tray is closed.
13	OUT SW	I	Loading OUT switch information terminal."L" when tray is opened.
14	ADJUST	I	E-F balance adjustment terminal. Not used.
15	CRCF	I	CRCF input terminal from Q109.
16	C4M	I	Reference clock input terminal.
18	XRST	I	Reset input terminal. Reset at high from low when power is turned on.
19	SCOR	I	Sub code sink input.
20	GND	I	Ground terminal.
21	Vss		Connect to ground.
22	SQCK	O	Sub code data read clock output.
23	SUBQ	I	Sub code data input.
25~30	ACCESS~POWER	O	Operation output terminal of servo system.
32	LSR	O	Laser diode control output terminal.Light on at low level.
33	OPEN	O	Loading motor control output. Tray opens at low level.
34	CLOSE	O	Loading motor control output. Tray closes at low level.
35	MUTE	O	Audio muting control output terminal. "H" active.
36	EMPH	O	Emphasis control output terminal. "H" active.
37	CLK	O	Serial command transfer clock output to servo system.
38	DATA	O	Serial command data output to servo system.
39	XLT	O	Serial command execution output to servo system.
40	SCLK	O	Status transfer clock output to Q701.
42	Vcc		+5V power supply terminal.

#### 4. Focus gain adjustment

Set the output of AF oscillator to 800Hz, 1~1.5Vp-p.

Play the track 2 of test disc.

Connect the oscilloscope and the AF oscillator as shown below.

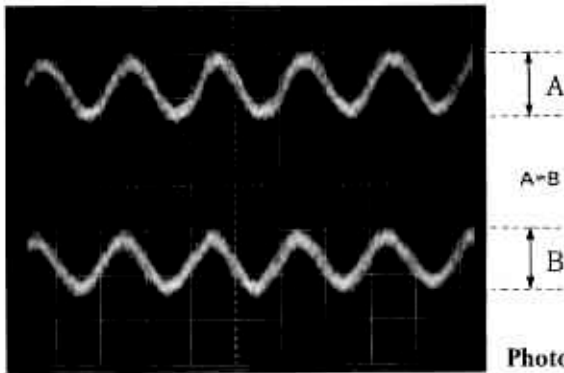
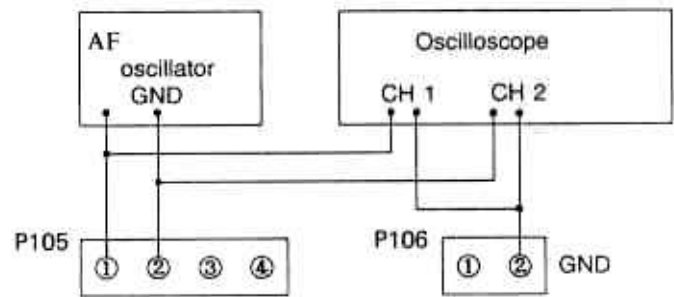


Photo 8

Adjust R122 until 800Hz components of channels 1 and 2 on oscilloscope become same level.

After adjustment, disconnect the AF oscillator and the oscilloscope.



Vertical : 0.5V/div.  
Horizontal: 1 ms/div.

#### 5. Tracking gain adjustment

Set the output of AF oscillator to 1.2kHz, 1~1.5Vp-p.

Play the track 2 of test disc.

Connect the oscilloscope and the AF oscillator as shown below.

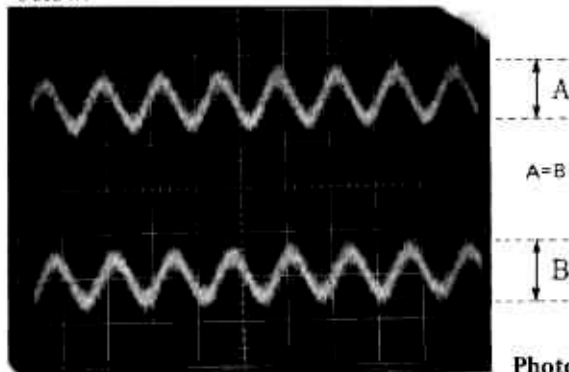
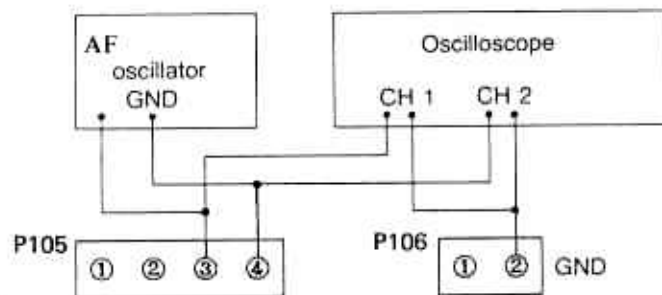


Photo 9

Adjust R125 until 1.2kHz components of channels 1 and 2 on oscilloscope become same level.

After adjustment, disconnect the AF oscillator and the oscilloscope.



Vertical : 0.5V/div.  
Horizontal: 0.5 ms/div.

#### 6. MSB adjustment

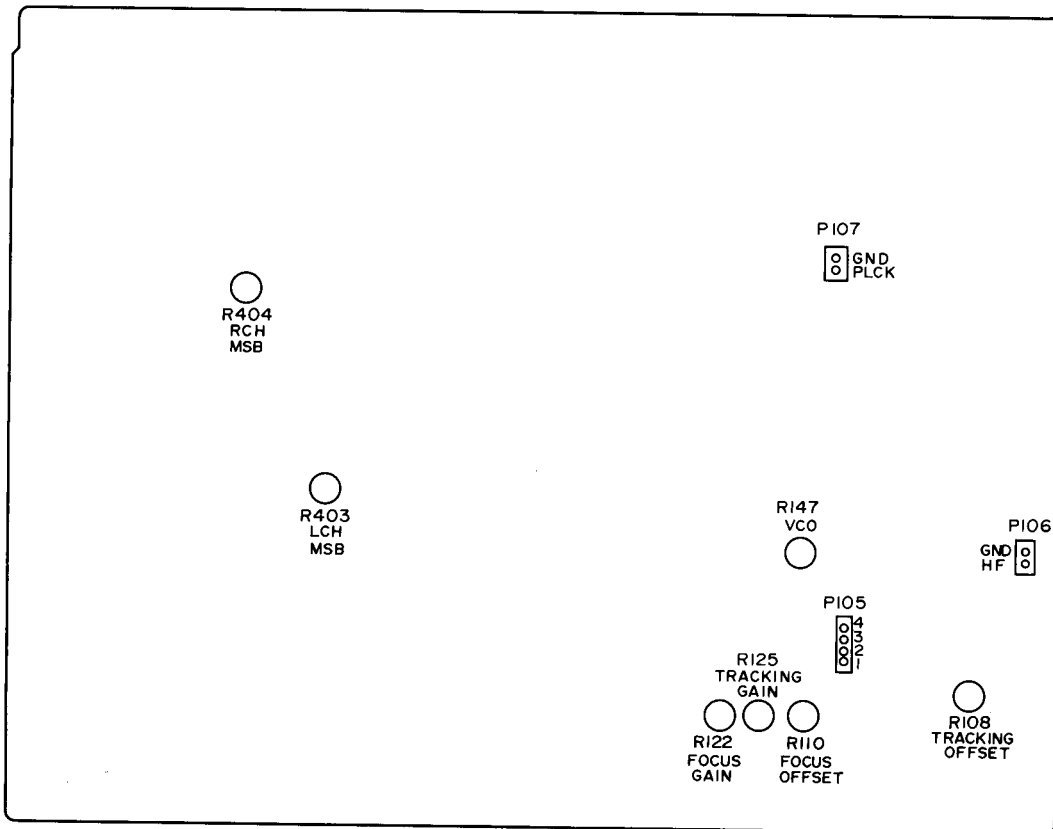
Play the track 2 of test disc.

Read the output signal and regard it as 0 dB. Then, play the track 17.

Adjust R403 (R404) so that the output level becomes -60dB.

NOTE: ( ): R channel

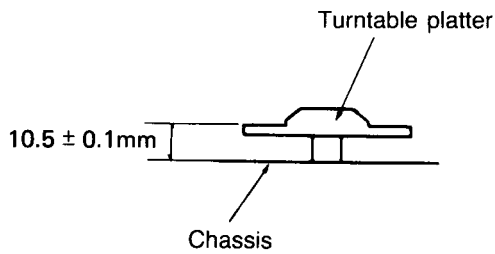




**Fig. 20 ADJUSTMENT POINT**

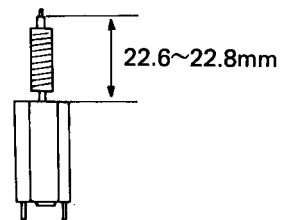
**MECHANISM ADJUSTMENT**

Height of turntable platter.



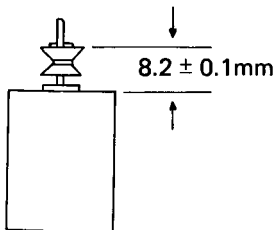
**Fig. 21**

**Slide motor**



**Fig. 22**

**Tray motor**



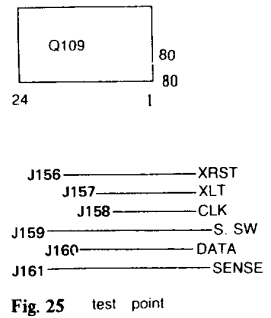
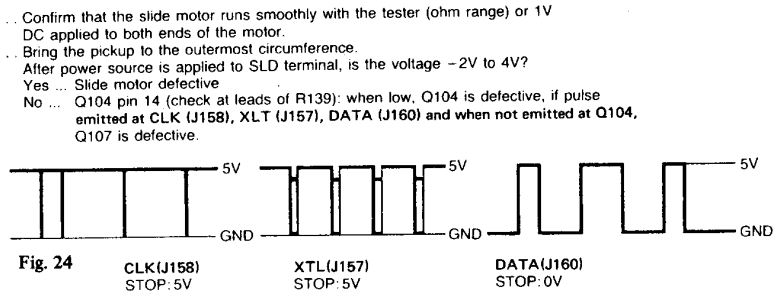
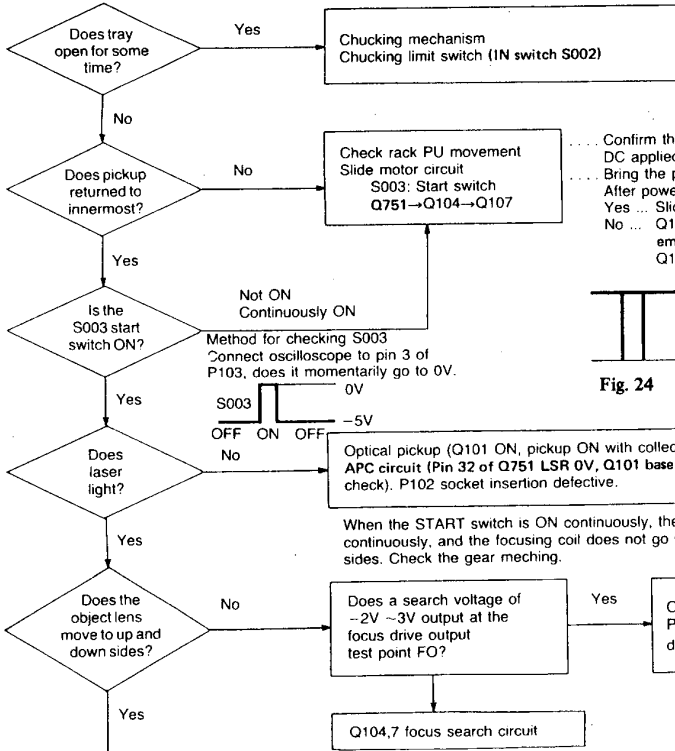
**Fig. 23**

# TROUBLESHOOTING GUIDE

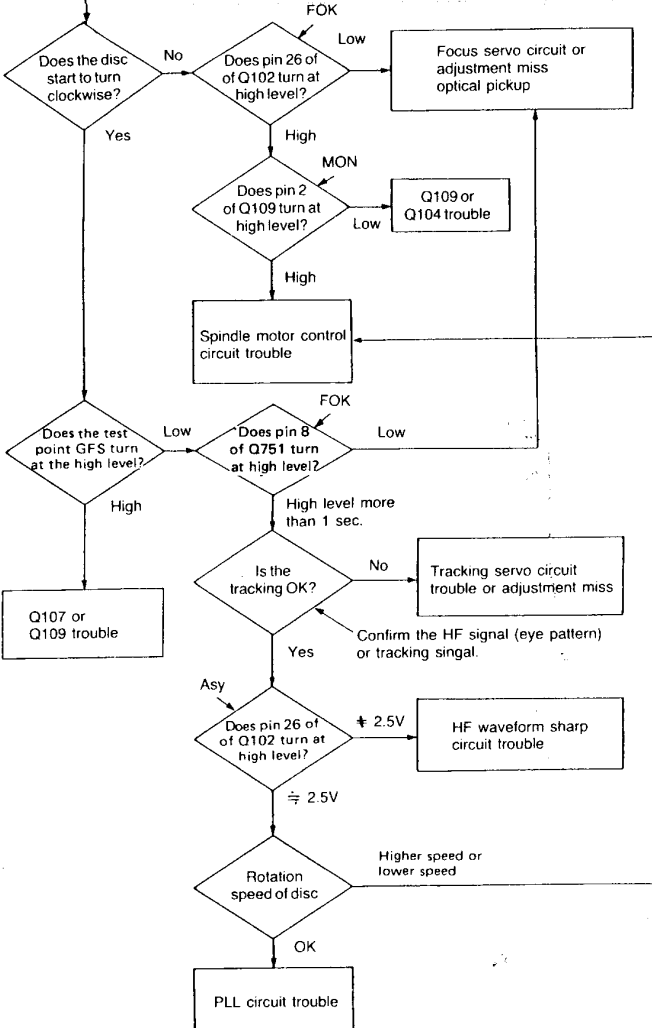
## Symptom: Defective reading (No RF signal emitted)

Load the disc on the tray, press OPEN/CLOSE key and close the tray. But, the total number of tunes are not indicated on the fluorescent indicator tube.

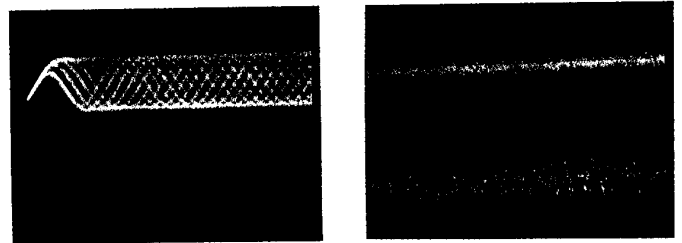
1. Remove the top cover.
2. Does the disc turn clockwise? . . . . . Yes . . . . . Next page  
No . . . . . Remove the bracket holder and arm ass'y. Check the following when turning on power without the disc.



NOTE: There is the possibility that the pickup lens is so dirty that it is impossible to read. Clean with a lens cleaner.



- Use the high impedance probe. (10:1)
- Play the track 2 of test disc. (YEDS-18)



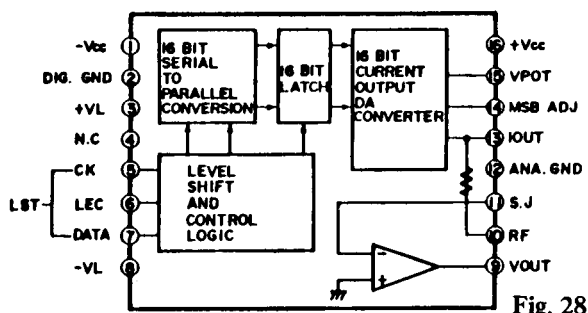
RF signal  
P106 pin 2 (HF)  
V: 50mV/div  
H: 0.5μS/div

Tracking signal  
P105 pin 4 (HF)  
V: 20mV/div  
H: 0.5mS/div

Photo 10

DXT700 DXT700

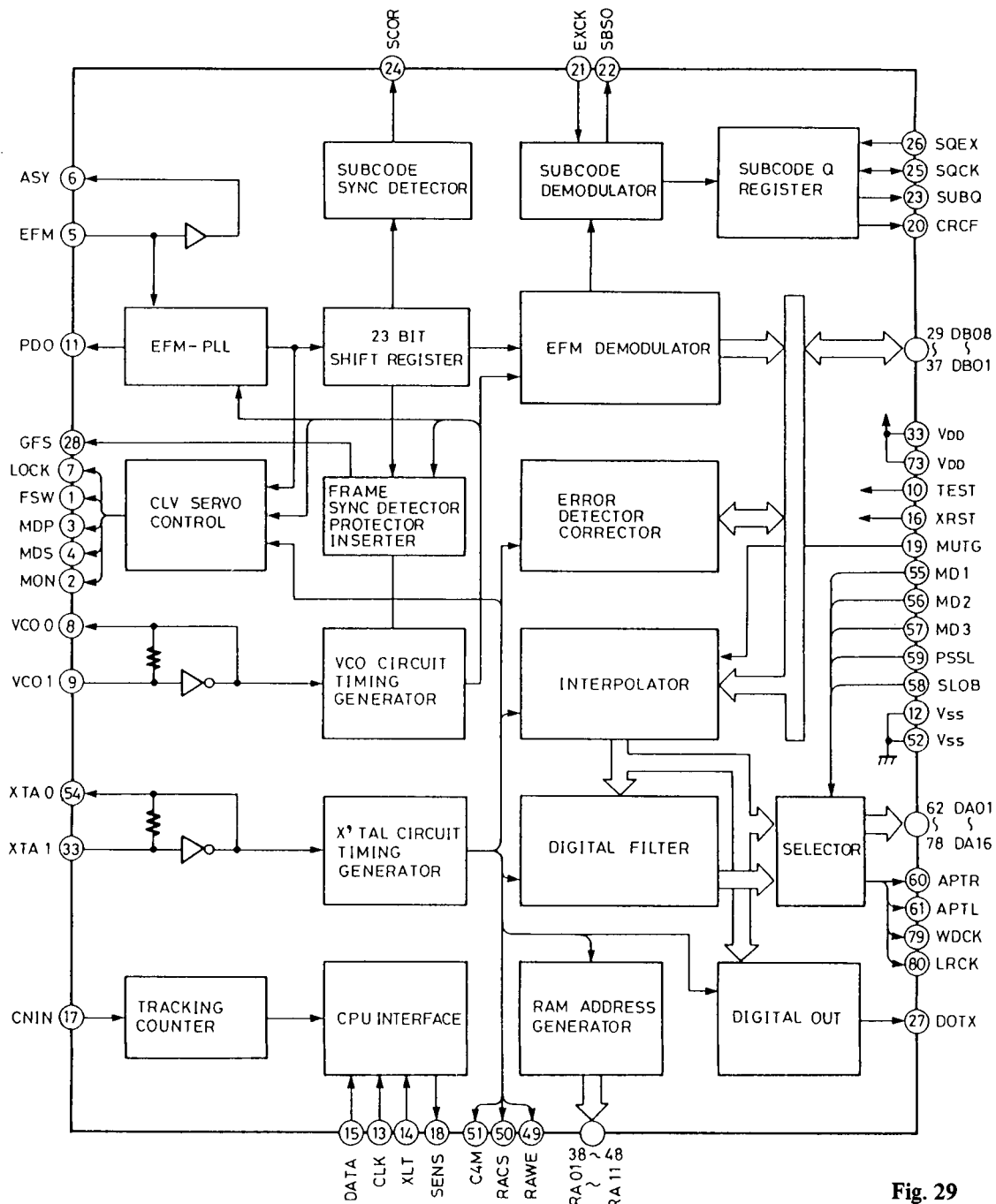
**Q401, Q402**  
**PCM-56P-L (D/A Converter)**



1	-Vcc	Analog power supply(-)	9	VOUT	Output
2	DIG. GND	Digital ground	10	RF	Feedback register
3	+VL	Logic voltage (+)	11	SJ	Operation amplifier input
4	N.C	Not used	12	ANA. GND	Analog ground
5	CK	Clock input	13	IOUT	Current output
6	LEC	Latch enable input	14	MSB ADJ	MSB adjustment terminal
7	DATA	Data input	15	VPOT	Meter terminal
8	-VL	Logic voltage (-)	16	+Vcc	Analog power supply (+)

**Fig. 28**

**Q109**  
**CXD1130Q (Digital Signal Processor)**



**Fig. 29**

Pin No.	Symbol	Function	Pin No.	Symbol	Function
1	FSW	Time constant switching output terminal of output filter of spindle motor	49	RAWWE	Write enable signal output to external RAM
2	MON	ON/OFF control output terminal of spindle motor	50	RACS	Chip selector signal output to external RAM
3	MDP	Drive output terminal of spindle motor. Rough control when mode CLV-S and phase control when mode CLV-P	51	C4M	Divider output of crystal. f=4.2336MHz
4	MDS	Drive output terminal of spindle motor. Speed control when mode CLV-P	52	Vss	Ground
5	EFM	EFM signal input terminal from RF amplifier	53	XTAI	Input terminal of crystal oscillator
6	ASY	Output terminal to control the slice level of EFM signal	54	XTAO	Output terminal of crystal oscillator
7	LOCK	GFS sampling terminal	55	MD1	Mode switching input terminals
8	VCOO	VCO output terminal. 8.6436MHz when lock to EFM signal	57	MD3	
9	VCOI	VCO input terminal	58	SLOB	Code switching input of audio data output.
10	TEST	0V	59	PSSL	Mode switching input of audio data output. Serial output at low level. Parallel output at high level
11	PDO	Phase comparator output terminal of EFM signal and VCO/2	60	APTR	Control output for aperture correction. High level when Rch.
12	Vss	Ground	61	APTL	Control output for aperture correction. High level when Lch.
13	CLK	Serial data transmitter clock input terminal from microcomputer	62	DA01	DA01 (LSB of parallel sound output) output when PSSL = H. C1F1 output when PSSL = L
14	XLT	Latch input terminal from microcomputer	63	DA02	DA02 output when PSSL = H. C1F2 output when PSSL = L.
15	DATA	Serial data input terminal from microcomputer	64	DA03	DA03 output when PSSL = H. C2F1 output when PSSL = L.
16	XRST	System rest input terminal. Reset at low level.	65	DA04	DA04 output when PSSL = H. C2F2 output when PSSL = L.
17	CNIN	Tracking pulse input terminal	66	DA05	DA05 output when PSSL = H. C2FL output when PSSL = L.
18	SENS	Inner condition output terminal correspond to address	67	DA06	DA06 output when PSSL = H. C2PO output when PSSL = L.
19	MUTG	Muting input terminal	68	DA07	DA07 output when PSSL = H. RFCK output when PSSL = L.
20	CRCF	CRC check output terminal of subcode Q	69	DA08	DA08 output when PSSL = H. WFCK output when PSSL = L.
21	EXCK	Clock input terminal for serial output of subcode	70	DA09	DA09 output when PSSL = H. PLCK output when PSSL = L.
22	SBSO	Serial output terminal of subcode	71	DA10	DA10 output when PSSL = H. UGFS output when PSSL = L.
23	SUBQ	Subcode Q output terminal	72	DA11	DA11 output when PSSL = H. GTOP output when PSSL = L.
24	SCOR	Subcode sink S0 + S1 output terminal	73	V <sub>DD</sub>	Power supply (5V)
25	SQCK	Clock terminal to read the subcode Q	74	DA12	DA12 output when PSSL = H. RAOV output when PSSL = L.
26	SQEX	Selector input terminal of SQCK	75	DA13	DA13 output when PSSL = H. C4LR output when PSSL = L.
27	DOTX	Digital output terminal	76	DA14	DA14 output when PSSL = H. C210 output when PSSL = L.
28	GFS	Indicator output of lock condition of frame sync	77	DA15	DA15 output when PSSL = H. C210 output when PSSL = L.
29	DB08	Data terminals of external RAM	78	DA16	DA16 (MSB of parallel sound output) output when PSSL = H. DATA output when PSSL = L
32	DB05				
33	V <sub>DD</sub>	+5V	79	WDCK	Strobe signal output. 176.4kHz when DF is on. 88.2kHz when DF is off.
34	DB04	Data terminals of external RAM	80	LRCK	Strobe signal output. 88.2kHz when DF is on. 44.1kHz when DF is off.
37	DB01				
38	RA01	Address output terminals of external RAM			
48	RA11				

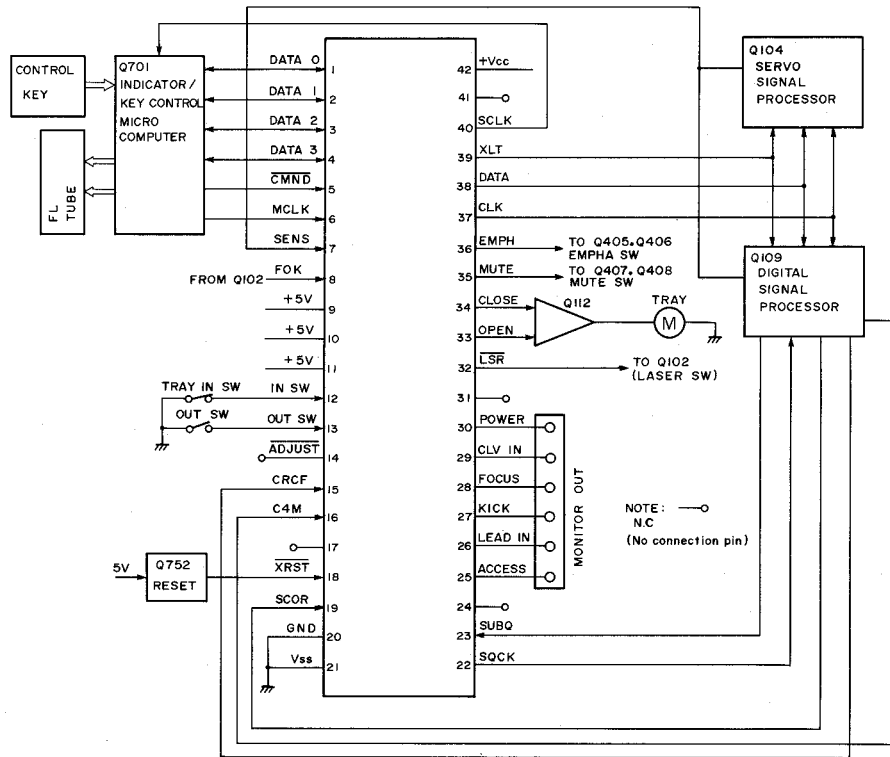


Fig. 38

**Q703  
8-BT-80GK (FL tube)**

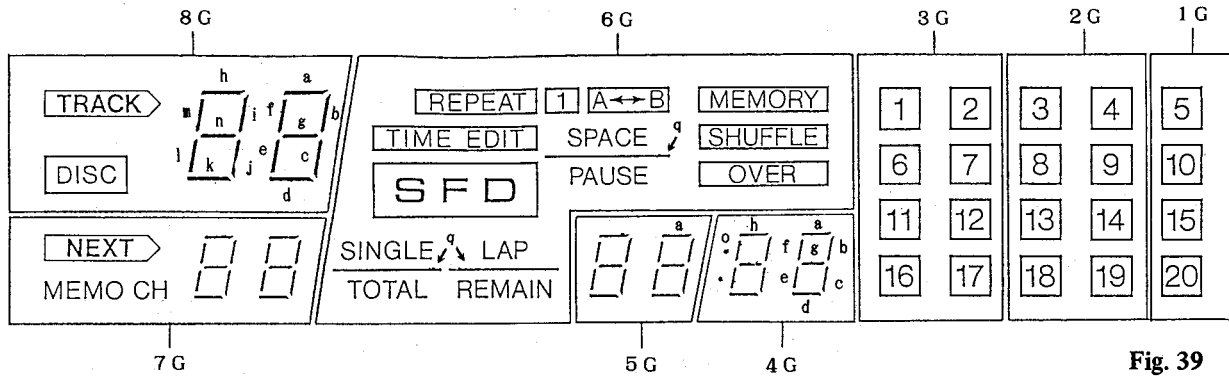


Fig. 39

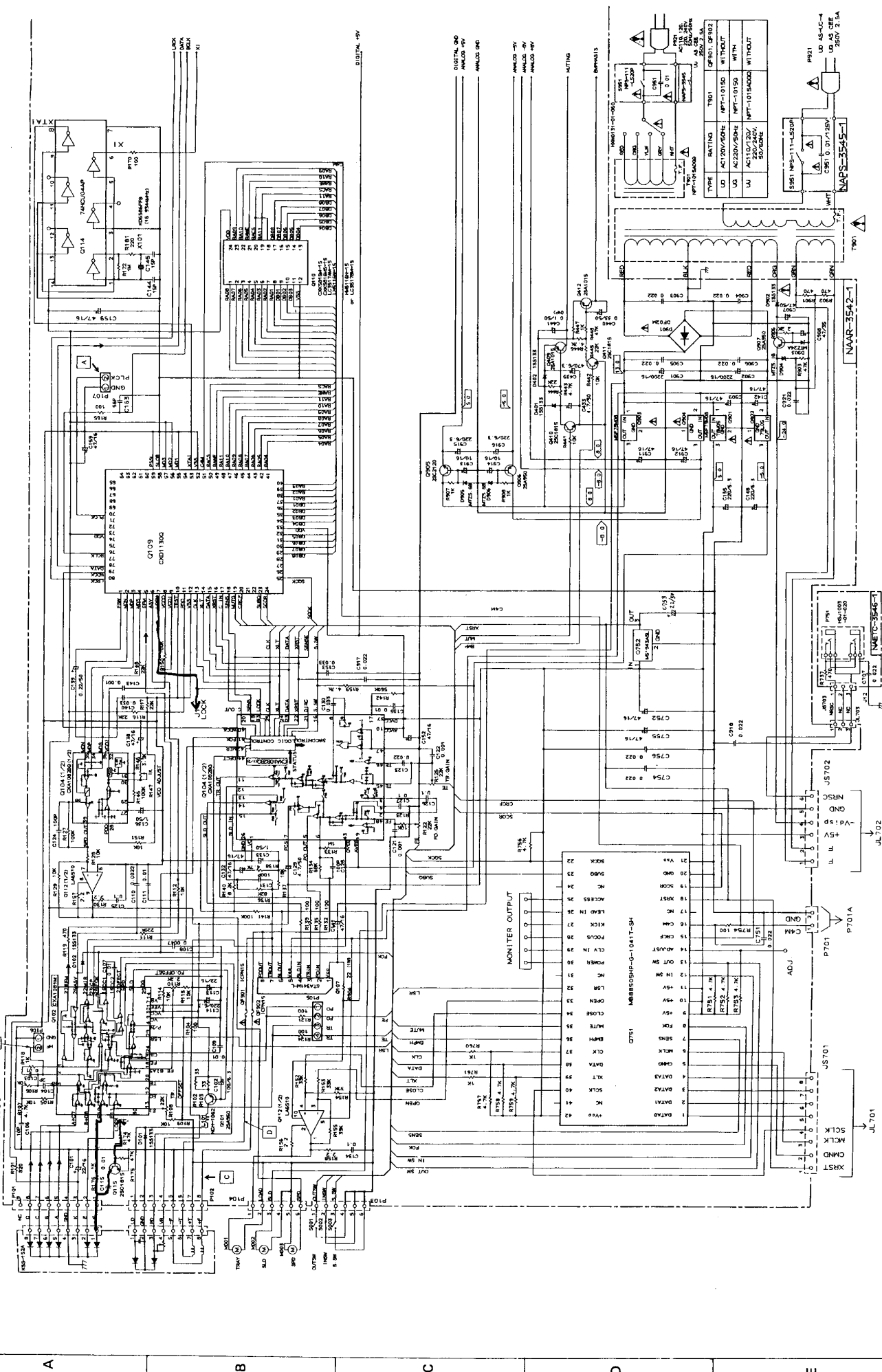
**ANODE CONNECTION**

	8 G	7 G	6 G	5 G	4 G	3 G	2 G	1 G
a	a	a	REPEAT	a	a	1	3	5
b	b	b	TIME EDIT	b	b	(1)	(3)	(5)
c	c	c	SFD	c	c	6	8	10
d	d	d	(SFD)	d	d	7	9	-
e	e	e	1	e	e	(6)	(8)	(10)
f	f	f	A↔B	f	f	2	4	-
g	g	g	SPACE	g	g	(2)	(4)	-
h	h	h	PAUSE	h	h	(7)	(9)	-
i	i	i	MEMORY	i	i	11	13	15
j	j	j	SHUFFLE	j	j	(12)	(14)	-
k	k	k	OVER	k	k	(16)	(18)	(20)
l	l	l	SINGLE	l	l	16	18	20
m	m	m	TOTAL	m	m	(11)	(13)	(15)
n	n	n	LAP	n	n	12	14	-
o	TRACK	NEXT	REMAIN	-	•	17	19	-
p	DISC	MEMO CH	-	-	-	(17)	(19)	-
q	-	-	≡	-	-	-	-	-

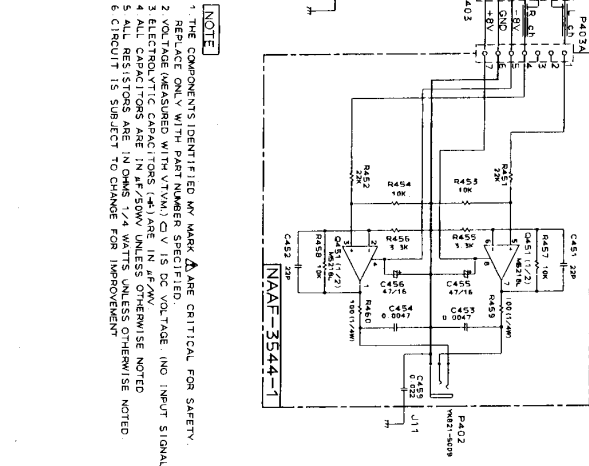
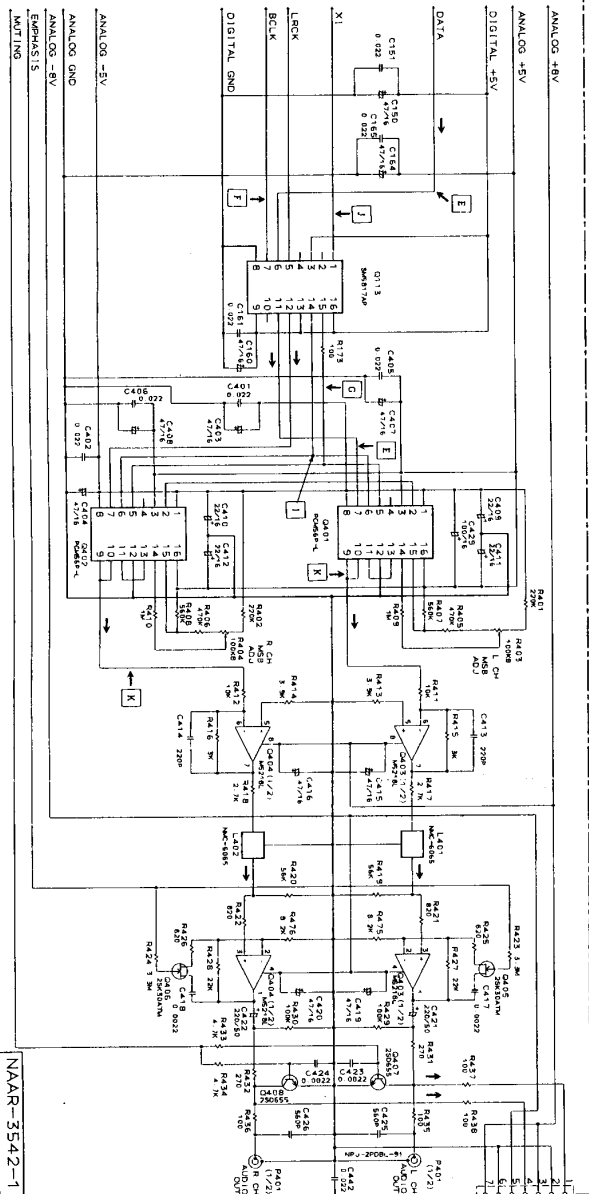
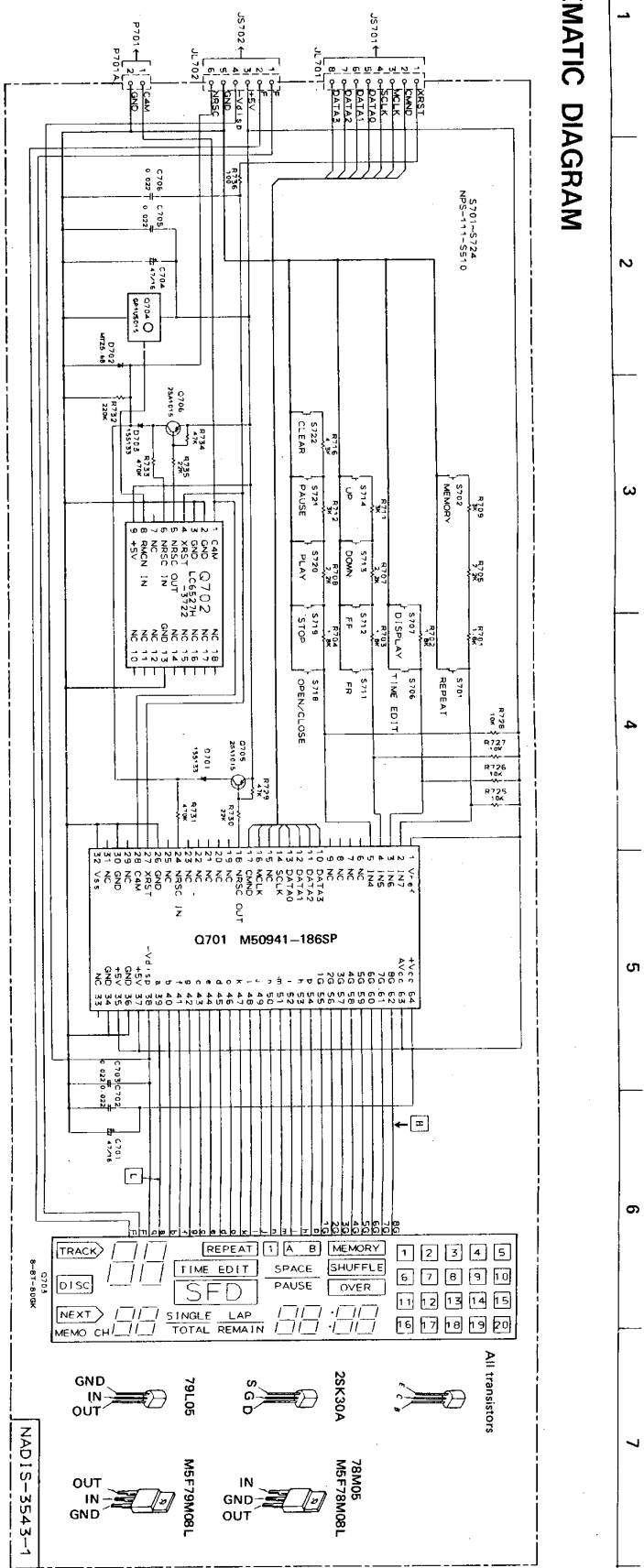
Fig. 40



SCHEMATIC DIAGRAM



SCHEMATIC DIAGRAM



**NOTE**

1. THE COMPONENTS IDENTIFIED BY MARK A ARE CRITICAL FOR SAFETY.
2. REPLACE ONLY WITH PART NUMBER SPECIFIED.
3. VOLTAGE MEASURED WITH VTVM. C.V IS DC VOLTAGE (NO INPUT SIGNAL).
4. ALL CAPACITORS ARE IN  $\mu\text{F}/50\text{V}$  UNLESS OTHERWISE NOTED.
5. ALL RESISTORS ARE IN  $\Omega$  UNLESS OTHERWISE NOTED.
6. CIRCUIT IS SUBJECT TO CHANGE FOR IMPROVEMENT.

**ONKYO CORPORATION**

# WAVEFORM OF EACH SECTION

- Use the high impedance (more than 10Mohm) probe. (10:1)
- Play the track 2 of test disc YEDS-18.

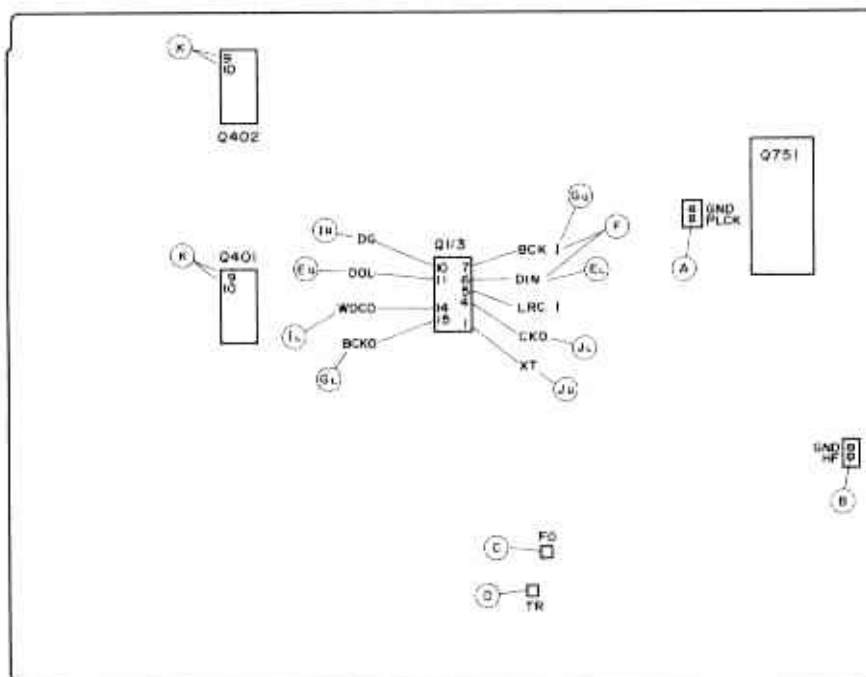
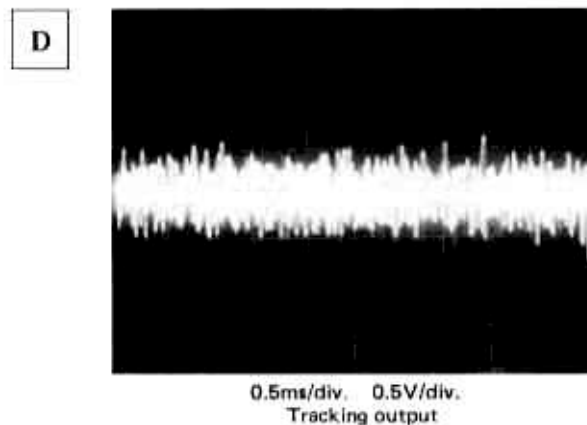
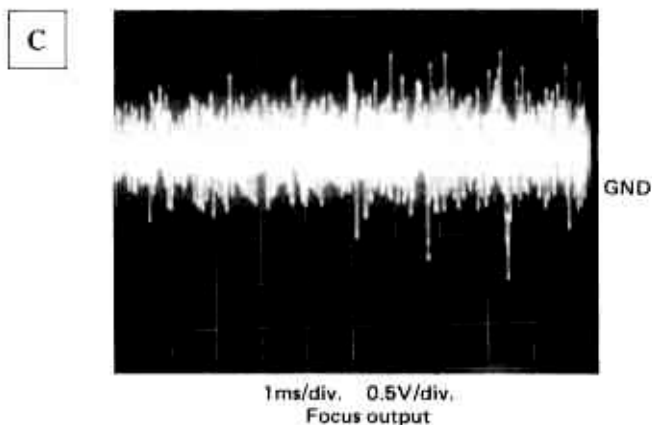
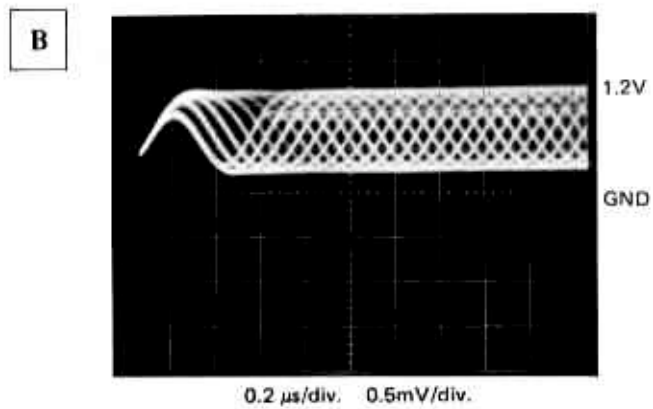
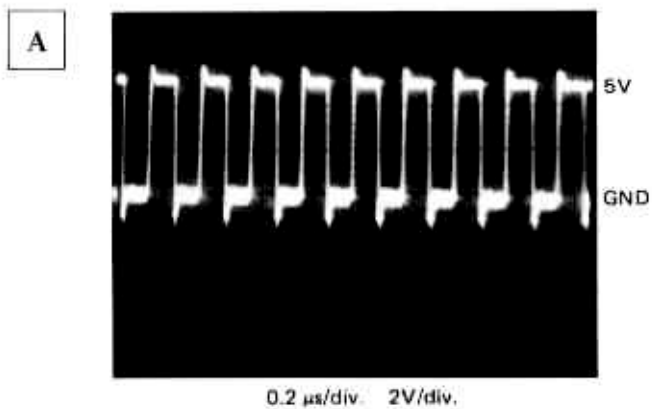
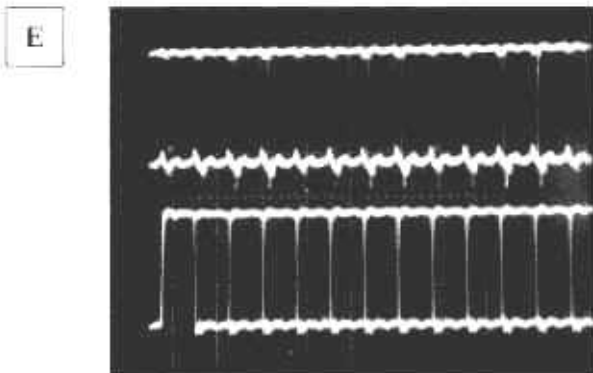
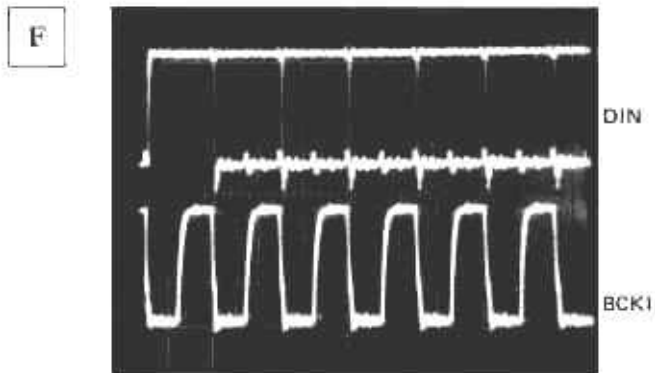


Fig. 41

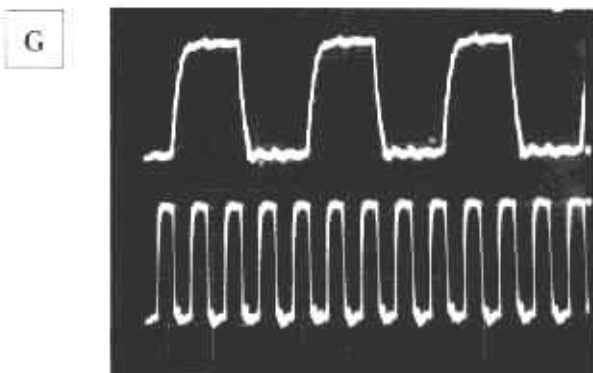




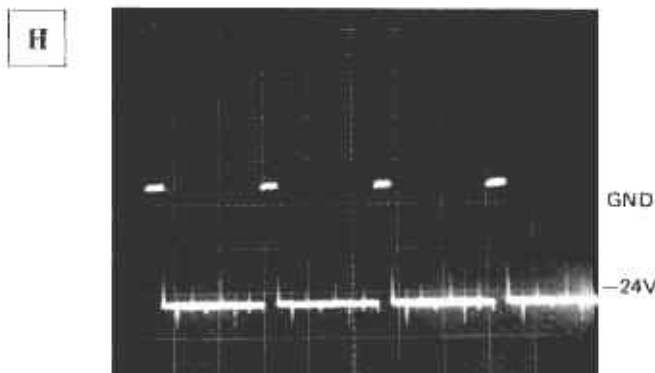
0.05  $\mu$ s/div. 2V/div.



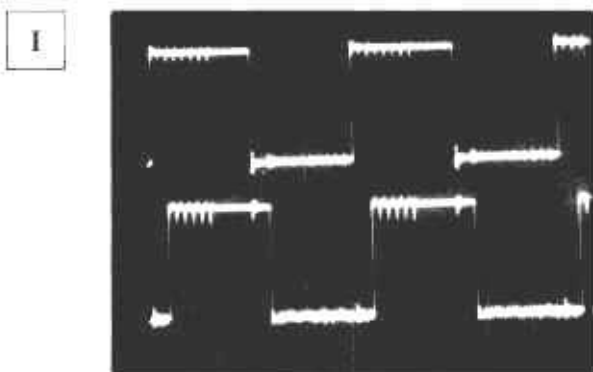
0.1  $\mu$ s/div. 2V/div.



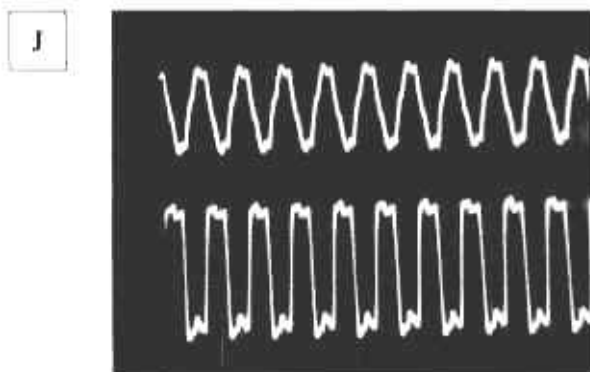
0.05  $\mu$ s/div. 2V/div.



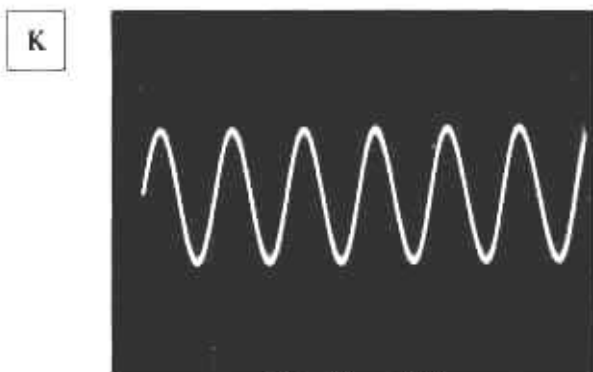
0.1ms/div. 10V/div.  
Grid output



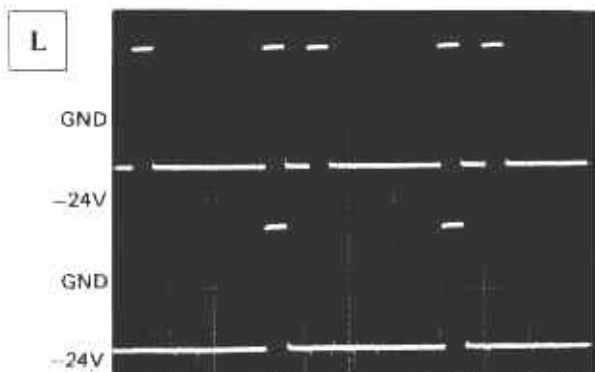
0.2  $\mu$ s/div. 2V/div



0.02  $\mu$ s/div. 2V/div



0.2ms/div. 2V/div.



Light on 2ms/div. 10V/div.  
U: Segment output  
L: Grid output

# PRINTED CIRCUIT BOARD-PARTS LIST

## MAIN CIRCUIT PC BOARD(NAAR-3542-1/1A)

CIRCUIT NO.	PART NO.	DESCRIPTION	CIRCUIT NO.	PART NO.	DESCRIPTION
Q102	22240029	CXA1081M	C130	371123334	0.033 $\mu$ F 5%, 50V, Mylar
Q104	22240223	CXA1082BQ	C132	354744709	47 $\mu$ F, 16V, Elect.
Q107	22240168	STA341M-L	C133	357480109	1 $\mu$ F, 50V, Elect.
Q109	22240095	CXD1130Q	C134	371121044	0.1 $\mu$ F 5%, 50V, Mylar
Q110	222990,	CXK5816M-15,	C135	371121034	0.01 $\mu$ F 5%, 50V, Mylar
	22240142,	CXK5816MS-15,	C136	354780109	1 $\mu$ F, 50V, Elect.
	22240032,	LC3517AM-15,	C138	354744709	47 $\mu$ F, 16V, Elect.
	22240203,	LC5116N-15,	C139	354782299	0.22 $\mu$ F, 50V, Elect.
	222882 or	HM6116FP-4 or	C140	371123334	0.033 $\mu$ F 5%, 50V, Mylar
	22240233	LC3517BM-15	C141,C142	354744709	47 $\mu$ F, 16V, Elect.
Q112	22240034	LA6510	C146	354744709	47 $\mu$ F, 16V, Elect.
Q113	22240237	SM5817AP	C148	354722219	220 $\mu$ F, 6.3V, Elect.
Q114	222755	74HC04P	C150,C152	354744709	47 $\mu$ F, 16V, Elect.
Q401,Q402	22240096	PCM56P-L	C153	371123334	0.033 $\mu$ F 5%, 50V, Mylar
Q403,Q404	222652	M5218L	C155	354722219	220 $\mu$ F, 6.3V, Elect.
Q751	22240236	MB88505HP-G-1041T-SH	C159,C160	354744709	47 $\mu$ F, 16V, Elect.
Q752	22240018	M51943ASL	C164	354744709	47 $\mu$ F, 16V, Elect.
Q901	222780052	78M05	C403,C404	354744709	47 $\mu$ F, 16V, Elect.
Q902	222790053	79L05	C407,C408	354744709	47 $\mu$ F, 16V, Elect.
Q903	222780085MIT	M5F78M08L	C409-C412	354742209	22 $\mu$ F, 16V, Elect.
Q904	222790085MIT	M5F79M08L	C413,C414	373302214	220pF 5%, 125V, Plastic (PP)
	<b>Transistors</b>		C415,C416	354744709	47 $\mu$ F, 16V, Elect.
Q101	2211503 or	2SA950-O or	C417,C418	371122224	2200pF 5%, 50V, Mylar
Q906,Q907	2211504	2SA950-Y	C419,C420	354744709	47 $\mu$ F, 16V, Elect.
Q115,Q410	2211254,	2SC1815-Y,	C421,C422	354782219	220 $\mu$ F, 50V, Elect.
Q411	2211255,	2SC1815-GR,	C423,C424	371122224	2200pF 5%, 50V, Mylar
	2211183 or	2SC1740-R or	C425,C426	373305614	560pF 5%, 125V, Plastic (PP)
	2212485	JC501-Q	C429	354741019	100 $\mu$ F, 16V, Elect.
Q405, Q406	2212375	2SK30ATM-GR	C438	354780479	4.7 $\mu$ F, 50V, Elect.
Q407,Q408	2211705 or	2SD655-E or	C439	354724719	470 $\mu$ F, 6.3V, Elect.
	2211706	2SD655-F	C440	354783399	0.33 $\mu$ F, 50V, Elect.
Q409,Q412	2211454,	2SA1015-Y,	C441	352981096	0.1 $\mu$ F, 50V, Non-polar elect.
	2211455,	2SA1015-GR,	C752,C755	354744709	47 $\mu$ F, 16V, Elect.
	2213074 or	2SA933-R or	C753	354780229	2.2 $\mu$ F, 50V, Elect.
	2212495	JA101-Q	C901,C902	354742229	2200 $\mu$ F, 16V, Elect.
Q905	2211163 or	2SC2120-O or	C907	354784709	47 $\mu$ F, 50V, Elect.
	2211164	2SC2120-Y	C908	354764709	47 $\mu$ F, 35V, Elect.
	<b>Diodes</b>		C909	354744709	47 $\mu$ F, 16V, Elect.
D101,D102	223163	1SS133	C911,C912	354744709	47 $\mu$ F, 16V, Elect.
D401,D402	223163	1SS133	C913,C914	354741009	10 $\mu$ F, 16V, Elect.
D901	223892	DF02M	C915,C916	354722219	220 $\mu$ F, 6.3V, Elect.
D902	223163	1SS133	<b>Resistors</b>		
D903	224652401 or	HZ24E-B1 or	R108	5210066	N06HR22KBD, Semi-fixed
	224452401	MTZ24A	R110	5210060	N06HR2.2KBD, Semi-fixed
D904	224650512 or	HZ5.1E-B2 or	R122,R125	5210066	N06HR22KBD, Semi-fixed
	224450512	MTZ5.1B	R147	5210058	N06HR1KBD, Semi-fixed
D905,D906	224650562 or	HZ5.6E-B2 or	R403,R404	5210070	N06HR100KBD, Semi-fixed
	224450562	MTZ5.6B	R904	441622204	22ohm 5%, 1W, Metal oxide film
	<b>X'tal</b>		<b>Plugs</b>		
X101	3010112	KD6586FFB	P101	25055153	NPLG-9P137
	<b>Coils</b>		P102	25055152	NPLG-8P136
L101	231023	NCH-1062	P103,P104	25055150	NPLG-6P134
L401,L402	232141	NMC-6065	P105	25055045	NPLG-4P33
	<b>Capacitors</b>		P106,P107	25055038	NPLG-2P29
C101,C113	354742209	22 $\mu$ F, 16V, Elect.	P403	25055151	NPLG-7P135
C102	354721019	100 $\mu$ F, 6.3V, Elect.	P701	25055146	NPLG-2P130
C103	371121034	0.01 $\mu$ F 5%, 50V, Mylar	<b>Terminal</b>		
C107,C109	371121034	0.01 $\mu$ F 5%, 50V, Mylar	P401	25045211	NPJ-2PDBL91, Output
C108	371124724	4700pF 5%, 50V, Mylar	<b>Sockets</b>		
C110	371122224	2200pF 5%, 50V, Mylar	JS701	25050272	NSCT-8P100
C111,C115	371121034	0.01 $\mu$ F 5%, 50V, Mylar	JS702	25050270	NSCT-6P98
C114	354722219	220 $\mu$ F, 6.3V, Elect.	<b>Radiator</b>		
C121,C122	371121024	1000pF 5%, 50V, Mylar	27160211-1		RAD68B
C123	371122234	0.022 $\mu$ F 5%, 50V, Mylar	<b>Screw</b>		
C125-C127	371121044	0.1 $\mu$ F 5%, 50V, Mylar	82143006		3P+6FN(BC), Pan head
C129	354780479	4.7 $\mu$ F, 50V, Elect.	<b>Fuses</b>		
			QF901,QF902	252112	ICPN15, IC protector <G>



# PRINTED CIRCUIT BOARD VIEW FROM BOTTOM SIDE

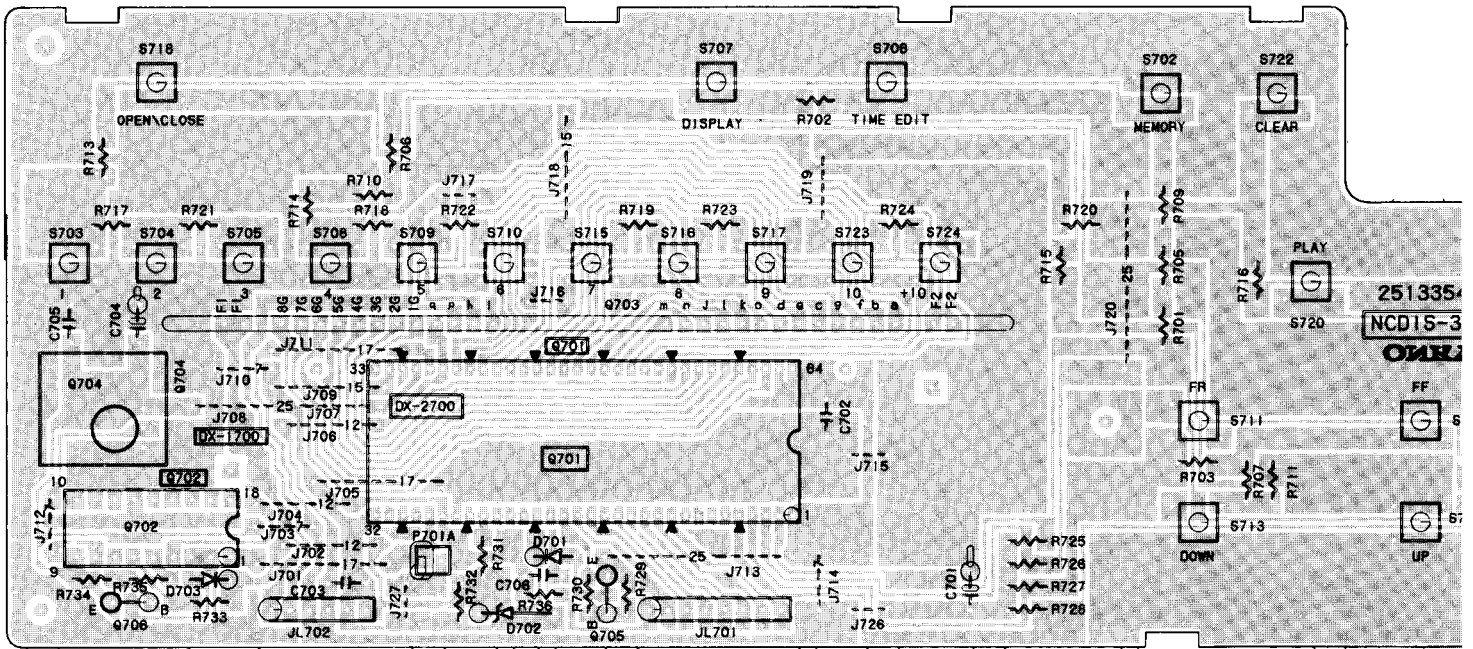


Fig. 43 DISPLAY CI

## DISPLAY CIRCUIT PC BOARD(NADIS-3543-1)

CIRCUIT NO.	PART NO.	DESCRIPTION
<b>ICs</b>		
Q701	22240235A	M50941-186SP
Q702	22240173	LC6527H-3722
Q704	24130001	GP1U501S
<b>FL tube</b>		
Q703	212072	8-BT-80GK
<b>Transistors</b>		
Q705, Q706	2211454, 2211455 or 2213074	2SA1015-Y, 2SA1015-GR or 2SA933-R
<b>Diodes</b>		
D701, D703	223163	1SS133
D702	224650562 or 224450562	HZ5.6EB2 or MTZ5.6B
<b>Capacitors</b>		
C701, C704	355744709	47 $\mu$ F, 16V, Elect.
<b>Switches</b>		
S701, S702	25035548	NPS-111-S510
S706, S707	25035548	NPS-111-S510
S711-S714	25035548	NPS-111-S510
S718-S722	25035548	NPS-111-S510
<b>Socket</b>		
	2000732	NSAS-4P688
<b>Holder</b>		
	27190696	FL tube

## HEADPHONE AMPLIFIER PC BOARD (NAAF-3544-1)

CIRCUIT NO.	PART NO.	DESCRIPTION
Q451	222652	M5218L
<b>Capacitors</b>		
C455, C456	354744709	47 $\mu$ F, 16V, Elect.
<b>Jack</b>		
P402	25045255	YKB21-5009
<b>Socket</b>		
P403A	2000987	NSAS-14P939

## POWER SUPPLY PC BOARD(NAPS-3545-1)

CIRCUIT NO.	PART NO.	DESCRIPTION
C951	3500065A	△ DE7150FZ103P AC400V/125V, Capacitor IS
S951	25035558 27300601	△ NPS-111-L520P, Power switch △ SB1925, Cover for C951

## SYNCRO. TERMINAL PC BOARD(NAETC-3546-1)

CIRCUIT NO.	PART NO.	DESCRIPTION
P751	25045172	HSJ1003-01-020, Terminal
JS703	25050267	NSCT-3P95, Socket

NOTE: <G>: Only 220/240V models

BLOCK DIAGRAM

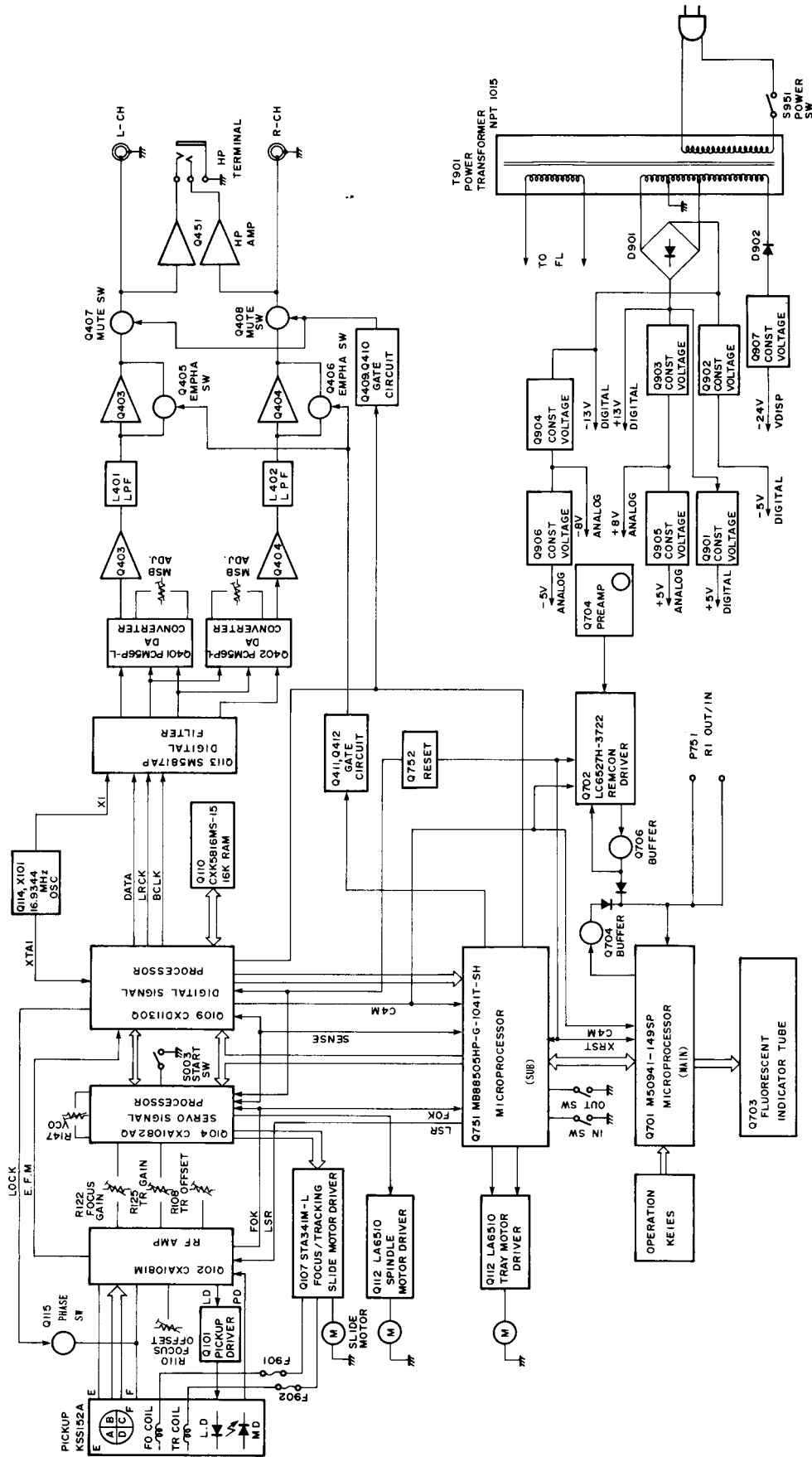


Fig. 47

## PACKING VIEW

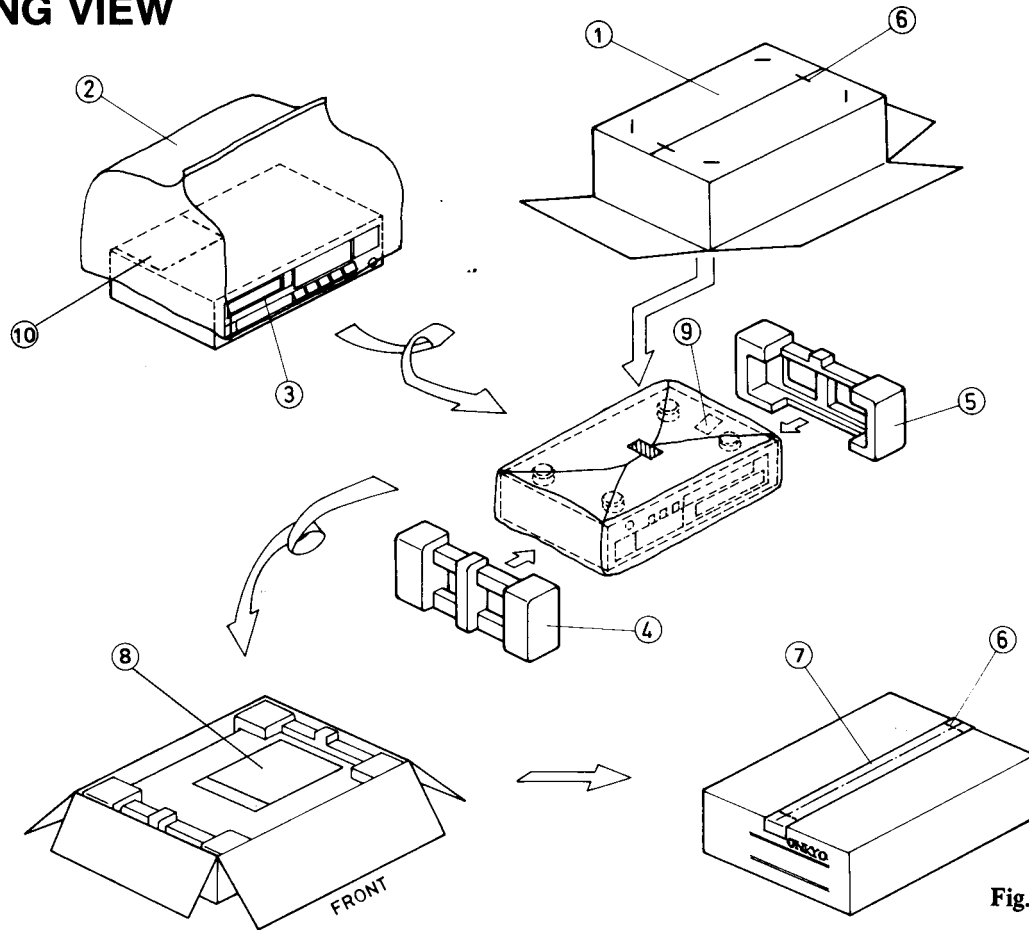


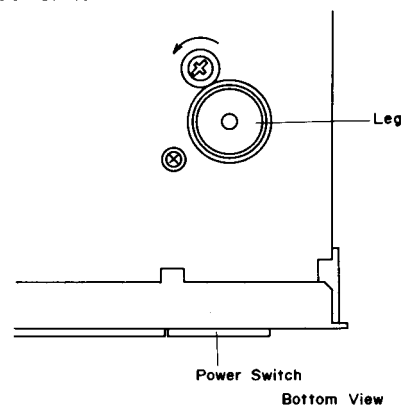
Fig. 48

REF. NO.	PART NO.	DESCRIPTION
1	29051873	Master carton box
2	29100037	500 × 650mm, Poly-vinyl bag
3	29095505	Protection sheet for tray panel
4	29091304	Pad R
5	29091303	Pad L
6	282301	Sealing hook
7	260012	50 × 600mm, Damplon tape
8	Accessory bag ass'y	
	2010098A	Connection cord
	2010169	Connection cord (RI)
	24140145	RC-145C, Remote control unit
	3010054	UM-3, Two batteries
	29341382A	Instruction manual <D>
	29341383	Instruction manual <G/W>
	25055040	CV-K-2, Conversion plug <W>
	29100097	350 × 250mm, Poly-vinyl bag
	29365019	Warranty card <UDN>
	29358002G	Service station list <UDN>
9	29361027	Caution label
10	29361011	Label

NOTE: <D>: Only 120V model  
 <G>: Only 220/240V models  
 <W>: Only Worldwide model  
 <UDN>: Only U.S.A. model

## Regarding the lock for transport protection

For the protection of the laser and optical parts during transport, a lock is provided on the bottom surface of the machine. When using the machine, turn the transport lock lever 180° counterclockwise to release the optical pickup. If the lock is not turned completely, the section at the beginning of the recording will be interrupted. When this symptom occurs, check the position of the lock lever.



## ONKYO CORPORATION

International Division: No. 24 Mori Bldg., 23-5, 3-chome, Nishi-Sinbashi, Minato-ku, Tokyo, Japan  
 Telex: 2423551 ONKYO J. Phone: 03-432-6981

## ONKYO U.S.A. CORPORATION

200 Williams Drive, Ramsey, N.J. 07446 Tel. 201-825-7950

SN0M3318 NS902 Printed in Japan